

w-NEXT2 DF

58 – 227 kW

Air conditioners for IT Cooling with Dual Fluid system.
For chilled water feeding.



The picture of the unit is indicative and may vary depending on the model

- PERIMETER INSTALLATION
- VERSION WITH SEPARATE FAN SECTION
- DUAL FLUID SYSTEM WITH ADDITIONAL COIL
- VARIABLE AIR AND WATER FLOW
- AIR DELIVERY FROM THE BOTTOM (UNDER)
- PLUG FANS WITH EC ELECTRIC MOTOR
- 2-WAY CHILLED WATER VALVE
- AIR SUCTION TEMPERATURE UP TO 45°C

Data Book: T_wNEXT2DF_1118_EN

INDEX

MEHITS CERTIFICATIONS.....	3
GENERAL CHARACTERISTICS	4
INSTALLATION.....	5
PRODUCT FEATURES AND BENEFITS	5
MODEL IDENTIFICATION	5
WORKING LIMITS	6
STORING TEMPERATURE.....	6
MAIN COMPONENTS.....	7
OPTIONAL ACCESSORIES	9
TECHNICAL DATA	10
DUAL FLUID SYSTEM.....	11
HYDRAULIC DIAGRAM.....	12
2-WAY VALVE FOR CHILLED WATER FLOW CONTROL (MAIN CIRCUIT AND DUAL FLUID CIRCUIT).....	12
ACOUSTIC DATA	13
ELECTRICAL DATA.....	13
WATER QUALITY	14
MICROPROCESSOR CONTROL SYSTEM.....	15
DEMAND LIMIT.....	16
OPTIONAL ACCESSORIES – DOUBLE POWER SUPPLY WITH AUTOMATIC TRANSFER SWITCH	17
OPTIONAL ACCESSORIES – NETWORK ANALYZER.....	18
OPTIONAL ACCESSORIES – FIRE / SMOKE SENSORS	19
OPTIONAL ACCESSORIES - CONDENSATE DISCHARGE PUMP	20
OPTIONAL ACCESSORIES – MODULATING STEAM HUMIDIFIER.....	21
OPTIONAL ACCESSORIES – DEHUMIDIFICATION SYSTEM.....	22
OPTIONAL ACCESSORIES – ELECTRIC HEATERS	23
OPTIONAL ACCESSORIES – 2-WAY BY-PASS VALVE FOR MAIN CHILLED WATER CIRCUIT.....	24
OPTIONAL ACCESSORIES - DOUBLE PANELS IN EUROCLASS A1	25
OPTIONAL ACCESSORIES – EPM ₁₀ 50% EFFICIENCY AIR FILTERS	25
OPTIONAL ACCESSORIES – NON RETURN MOTORIZED DAMPER.....	26
OPTIONAL ACCESSORIES - PLENUM ON AIR RETURN	28
OPTIONAL ACCESSORIES – DIRECT FREE-COOLING PLENUM	29
OPTIONAL ACCESSORIES – COOLNET.....	31
OPTIONAL ACCESSORIES – ADAPTIVE SET-POINT	31
OPTIONAL ACCESSORIES – CLOUD PLATFORM: WEB SERVICES BASED ON CLOUD TECHNOLOGY FOR REMOTE MONITORING AND MANAGEMENT OF AIR CONDITIONING PLANTS	32
MACHINE DRAWINGS	33
HOLE IN THE RAISED FLOOR.....	44
EXAMPLE FOR MACHINES NOISE EMISSION CALCULATION.....	45
VALVE PRESSURE DROP CALCULATION AS FUNCTION OF WATER FLOW RATE.....	46

MEHITS CERTIFICATIONS



SYSTEM CERTIFICATIONS

ISO 9001 CERTIFICATION – MEHITS S.p.A.
Quality Management System



ISO 14001 CERTIFICATION – MEHITS S.p.A.
Environmental Management System



BS OHSAS 18001 CERTIFICATION – MEHITS S.p.A.
Occupational Health and Safety Management System

PRODUCT CERTIFICATIONS BY COUNTRY



CE MARKING
MEHITS units are in compliance with the European Directives in force.



CCC – CQC CERTIFICATION
(People’s Republic of China)



EAC CERTIFICATION
(Russian Federation, Belarus, Kazakhstan)



GENERAL CHARACTERISTICS



UNDER

Downflow air delivery and separate fan section

Air conditioners for IT Cooling with Dual Fluid system.

- Chilled water feeding;
- Variable air and water flow;
- Plug fans with EC electric motor.
- **Separate fan section.**
- **Two independent cooling systems:** Double chilled water coil.

These series are offered in 7 models, available in the following version:

- Downflow version (Under) characterized by air intake from the top and air delivery from the bottom of the unit.

The sections are supplied separately and have to be connected during units installation.

The first section contains air filters and cooling coil, the second the supply fans.

The supply fans section is to be installed in the floor void and, with the simple shift of the paneling, you can obtain the air delivery from the front or from the rear of the unit.

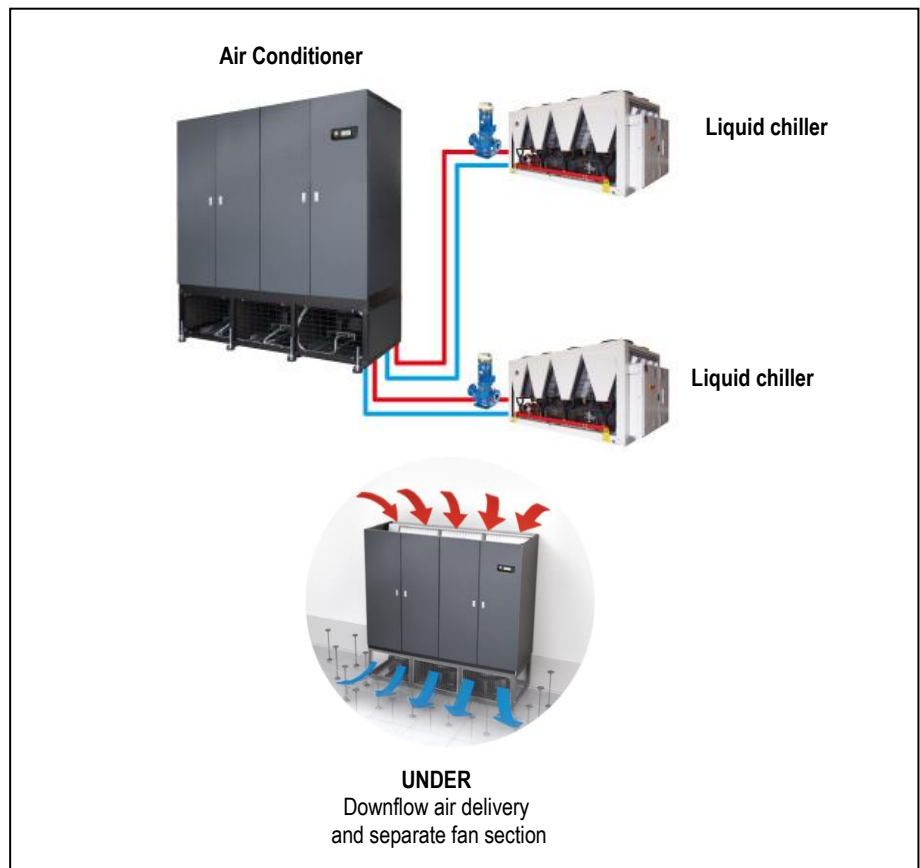

The machines are made for indoor installation.

The constructive solutions and the internal lay-out allow high application flexibility and the frontal access to the main components for the inspection and routine maintenance.

The installation requires electrical and hydraulic connections.

Final assembly on all machines before shipment including running test, reading and monitoring of operating parameters, alarms simulation and visual check.

INSTALLATION

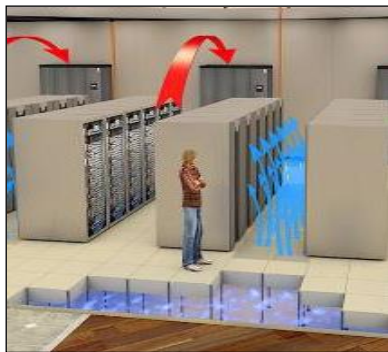

DOWNFLOW VERSION (Under)

Typical installation is on the perimeter.

The units are placed along the perimeter of the data center. Air suction from the top of the unit and air delivery in the underfloor void.

The air distribution is achieved by special tiles placed in front of the racks row, forming cold aisle for air diffusion. On the rear of the racks is expelled the hot air (hot aisle) then aspirated by the unit.

For an optimal installation is advisable to provide the cold aisle containment.

Some solutions provide a service corridor around the server rooms where to place the units. In this case it is necessary to provide the air intake plenum for each unit. With this solution all the space in the Data Center is available for the installation of racks.

OPTIONAL

An extensive list of accessories allows the unit to adapt effectively to the real needs of the system, reducing the time and cost of installation.

PRODUCT FEATURES AND BENEFITS

- **Dual Fluid System:** Two independent cooling systems: Double chilled water coil;
- Wider range and performance increasing;
- Optimization of the hydraulic circuit;
- New plug fans with EC electric motors with impeller in composite material, which guarantees a reduction of power consumption;
- New fans electric motor that do not require maintenance;
- Improvement of the control software with advanced control logic;
- Increased cooling density, up to 85,7 kW per m²;
- Total front access for the routine maintenance;
- Panels fully removable to facilitate the operations of extraordinary maintenance;

MODEL IDENTIFICATION

Air conditioners for IT Cooling for chilled water feeding
model: w-NEXT2 DF U 065 E4

w-NEXT2	Series with separate fan section
DF	Unit type DF – with dual fluid system Two independent cooling systems: Chilled water coil, direct expansion coil,
U	Air delivery U = under – downflow air delivery
065	Model / Cooling capacity (kW) at nominal conditions
E4	Size

WORKING LIMITS

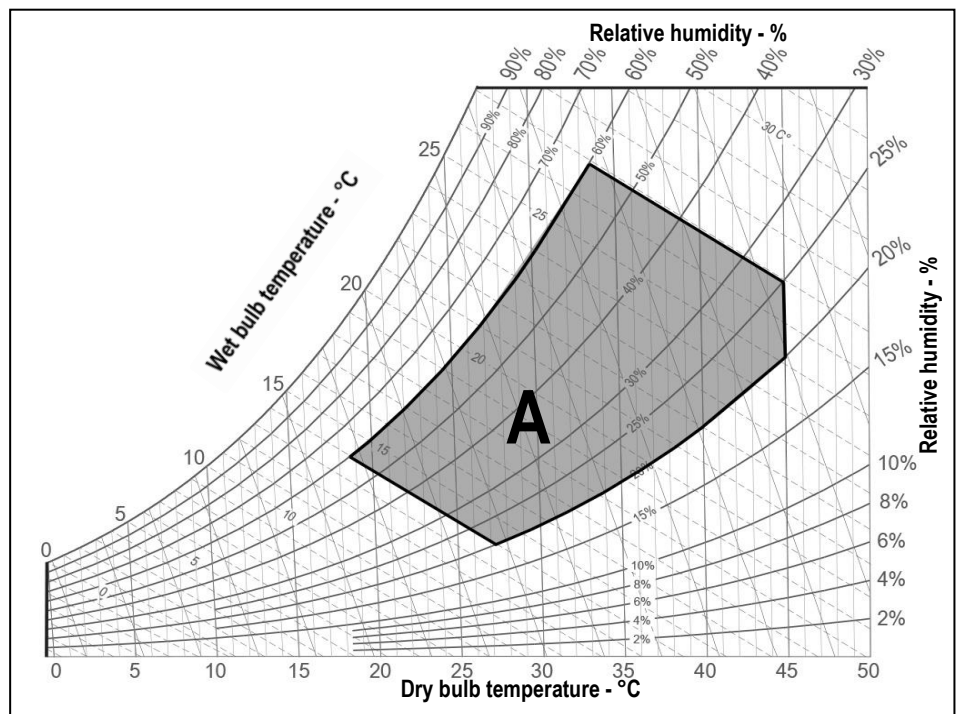

ROOM AIR CONDITIONS

Room air temperature:

- 14°C minimum temperature with wet bulb.
- 27°C maximum temperature with wet bulb.
- 18°C minimum temperature with dry bulb.
- 45°C maximum temperature with dry bulb.

AREA "A". Machine operating envelope.

Room air humidity:

- 20%RH minimum relative humidity.
- 60%RH maximum relative humidity.

CHILLED WATER TEMPERATURE

- 6°C Minimum chilled water inlet temperature
- 25°C Maximum chilled water inlet temperature
- ΔT 3°C Minimum temperature difference between chilled water inlet and outlet
- ΔT 10°C Maximum temperature difference between chilled water inlet and outlet

HYDRAULIC CIRCUIT

- ΔP 5-150kPa Pressure drop range of the hydraulic circuit.
- 10 Bar Maximum working pressure of the hydraulic circuit

POWER SUPPLY

- $\pm 10\%$ Maximum tolerance of the supply voltage (V)
- $\pm 2\%$ Maximum unbalancing of the phases.

STORING TEMPERATURE

If the machine is not installed on receipt and is stored for a long time, store it in a protected place, at temperatures ranging between -30°C and 50°C in absence of superficial condensation and direct sun light.

MAIN COMPONENTS

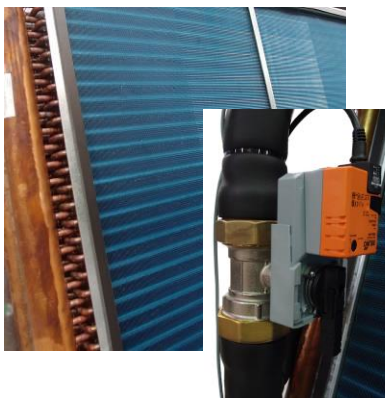

FRAMEWORK

- Base in aluminium extrusion, painted with epoxy powders. Colour RAL 9005;
- Frame in aluminium profile, painted with epoxy powders. The inner frame is provided with seals for the panels. Colour RAL 9005;
- Panels in galvanized steel sheet with protective surfaces treatment in compliance with UNI ISO 9227/ASTMB117 and ISO 7253, and painted with epoxy powders. Colour RAL 7016 hammered;
- Panels insulated with polyurethane foam and seals to ensure air tight.
- Hinged front panels with quick release removal system.
- Total front access for routine maintenance.
- Removable lateral and back side panels.
- Air flow UNDER version:
 - Air intake from the top and air delivery from the bottom.
- Compartment for electrical panel on unit front for direct access to control and regulation devices;

FILTER SECTION

- Washable air filters with COARSE 60% efficiency (according to ISO EN 16890), with cells in synthetic fibre and metallic frame.
- Air filters access:
 - From upper side for all machines

COOLING SECTION

- Heat exchanger coil with internally corrugated copper tubes and high efficiency aluminium fins, specifically developed to provide high heat transfer and lower pressure drops.
- Finned pack with hydrophilic treatment that assure the condensate water drop, high thermal conductivity and does not favour the growth of micro-organisms.
- 2-way motorized valve for water flow regulation with 0÷10 VDC control actuator and emergency manual control.
- Frame in galvanized steel.
- Condensate tray in peraluman with PVC flexible discharge pipe.
- Air temperature sensors upstream and downstream the cooling section, with control, regulation and limitation functions.
- Temperature probe on chilled water inlet.

COOLING SECTION – DUAL FLUID

- Chilled water 4 rows cooling coil with copper tubes, aluminium fins and galvanized steel frame.
- 2-way motorized valve with 0÷10 VDC control actuator and emergency manual control.
- Temperature probe on water inlet.
- Hydraulic pipes in copper with anticondensate insulation.



SEPARATE FANS SECTION

The fan section is separated and is designed to be fixed under the machine.

The fan section provides the air discharge from the front and can be installed in the raised floor void or directly on the floor for downflow air delivery.

It is possible to provide the air flow towards the rear of the machine by moving the panels and the fan guard.

The fans section includes:

- Height adjusting rubber holders.
- Centrifugal fans with backward curved blades with wing profile, single suction and without scroll housings (Plug-fans), directly coupled to external rotor electric motor.
 - Impeller in composite material exempt from rust formation.
 - Brushless type synchronous EC motor with integrated electronic commutated system and continuous variation of the rotation speed. The motor rotation control is obtained with the EC system (Electronic Commutation) that manage the motor according to the signal coming from the microprocessor control.
- Fans control through ModBus. In case of failure, the control stops the interested fan indicating the type of fault. The machine with more than one fan is not stopped.
- Dividing panels in galvanized steel sheet, unpainted.
- Fan guard with rubber support on air intake and delivery

ELECTRICAL PANEL

In accordance with EN60204-1 norms, suitable for indoor installation, complete with:

- Main switch with door lock safety on frontal panel;
- Magnetothermic switches for supply fans.
The supply fans equipped with EC electric motor and don't require contactors.
- Transformer for auxiliary circuit and microprocessor supply.
- Terminals:

OUTLETS

- Voltage free deviating contact for General Alarm 1-2.
- Voltage free contact for supply fans status.
- Voltage free contact for fire / sensor (the sensors are accessory)

INLETS

- External enabling.
- Power supply 400/3+N/50.

CONTROL SYSTEM

Microprocessor control system with graphic display for control and monitor of operating and alarms status.

The system includes:

- Built-in clock for alarms date and time displaying and storing;
- Built-in memory for the storing of the intervened events (up to 200 events recorded);
- Predisposition for additional connectivity board housing (MBUS RS485/JBUS, MBUS RS232/JBUS for GSM modem, LON, BACnet for Ethernet (SNMP- TCP/IP), BACnet for MS/TP). The electronic cards are optional accessories.
- Main components hour-meter;
- Non-volatile "Flash" memory for data storage in case of power supply faulty;
- Menu with protection password;
- LAN connection (max 10 units).

OPTIONAL ACCESSORIES

The descriptions of these additional components can be found in Chapter OPTIONAL ACCESSORIES.

- Double power supply with automatic change-over. Not compatible with “oversized electric heaters” and “oversized humidifier” optional accessories.
- Network analyzer: multifunction utility for calculating and displaying the machine electrical measurements.
- Smoke sensor. Supplied in mounting kit.
- Fire sensor. Supplied in mounting kit.
- Condensate drain system. Supplied in mounting kit. The system includes pump with activation float and 10 linear meters long discharge pipe.
- Modulating steam humidifier with immersed electrodes with electronic control. The optional foresee the combined Temperature / Humidity sensor on return air.
- Dehumidification system. The optional foresee the combined Temperature / Humidity sensor on return air.
- 2-way motorized valve with 0÷10 VDC control actuator and emergency manual control for the third way (by-pass) of the main chilled water hydraulic circuit (size E10 excluded). The valve is in combination with the main water flow control valve.
- Electric heating system consisting of aluminium armoured elements with integral fins
- Double panels in Euroclass A1.
- Washable air filter with ePM₁₀ 50% efficiency (according to ISO EN 16890).
- Non-return air damper driven by electric servomotor installed on the machine air return.
- Empty plenum. Available in Euroclass A1.
- Plenum for direct free-cooling on air intake. The optional foresee the combined Temperature / Humidity sensor on machine air suction and the Temperature sensor for ambient air.
- COOLNET: application software to maximize energy saving in Load Sharing.
- ADAPTIVE SET POINT: software that optimizes the operation of liquid chillers connected to the indoor air conditioners by control of the effective room thermal load.
- KIP LINK: Keyboard in your pocket. Allows to operate on the unit with smartphone or tablet.
- CLOUD PLATFORM: Web services based on cloud technology for remote monitoring and management.

OTHER ACCESSORIES

- Automatic system for the air pressure control in the under floor. The system controls the supply fans rotation speed in order to keep constant the air pressure in the under floor via a differential pressure transmitter connected to the microprocessor control.
Restriction: The optional is not compatible with COOLNET.
- Differential pressure switch on the air side for clogged filters alarm signal.
- Under floor water alarm through sensor to be placed on the floor.
- Additional underfloor water sensor kit.
- Combined Temperature / Humidity sensor on return air.
- Temperature sensor for outdoor installation.
- Combined Temperature / Humidity sensor for remote installation. The optional is added to the standard sensor on machine air suction.
- Microprocessor control accessories:
 - Remote terminal.
 - Serial card MBUS RS485/JBUS.
 - Serial card MBUS RS232/JBUS for GSM modem.
 - Serial card LON.
 - Serial card BACnet for Ethernet – SNMP – TCP/IP.
 - Serial card BACnet for MS/TP.
 - Temporary microprocessor power supply. The system guarantees the microprocessor power supply for a few minutes, in case of supply voltage failure.
 - Analogue set point compensation according to an external analogue signal at Customer care.
The microprocessor control, through the additional module “expansion card”, can manage a compensation signal of the return air setpoint by analogue input (0...1V; 0...5V; 0,5...4,5V; 4...20mA; 0...20mA). The compensation curve allows to assign a temperature setpoint offset respectively to the minimum and maximum signal managed by the input.

WARNING

The Manufacturer reserves the right to accept the matching of the optional installed on the machine.

TECHNICAL DATA

MODEL		065	088	096	127	148	173	226
SIZE		E4	E5	E6	E7	E8	E9	E10
VERSION (1)		U	U	U	U	U	U	U
COOLING CAPACITY (2)								
Total	kW	58,2	89,2	97,9	127	149	175	227
Sensible	kW	47,8	69,9	78,8	104	121	144	182
SHR (3)		0,82	0,78	0,80	0,82	0,81	0,82	0,80
"EC" SUPPLY FANS	n.	1	2	2	3	3	3	4
Air flow	m ³ /h	13950	19700	23000	30000	34000	41000	52000
Nominal external static pressure	Pa	20	20	20	20	20	20	20
Maximum external static pressure	Pa	165	49	209	40	205	24	107
Fans power input (4)	kW	2,13	5,18	4,8	7,72	7,32	8,43	10,1
COOLING COIL								
Water flow rate (2)	m ³ /h	10,00	15,37	16,84	21,85	25,74	30,13	39,24
dP coil + valve (2)	kPa	56	85,2	65,2	65,3	95,3	94,3	84,5
Water volume	l	17,6	23,1	27,1	31,4	36,4	43,2	53
AIR FILTERS	n.	-	-	-	8	10	12	12
Filter area	m ²	2,66	3,32	4,05	4,89	5,72	6,7	8,37
Efficiency (ISO EN 16890)	COARSE	60%	60%	60%	60%	60%	60%	60%
POWER SUPPLY	V/Ph/Hz	400/3+N/50	400/3+N/50	400/3+N/50	400/3+N/50	400/3+N/50	400/3+N/50	400/3+N/50
ENERGY EFFICIENCY INDEX (2)								
EER Energy Efficiency Ratio	kW/kW	27,3	17,2	20,4	16,5	20,4	20,8	22,5
DIMENSIONS AIR HANDLING SECTION								
Length	mm	1305	1630	1875	2175	2499	2899	3510
Width	mm	930	930	930	930	930	930	930
Height	mm	1980	1980	1980	1980	1980	1980	1980
DIMENSIONS SUPPLY FANS SECTION								
Length	mm	1305	1630	1875	2175	2499	2899	3510
Width	mm	905	905	905	905	905	905	905
Height	mm	600	600	600	600	600	600	600
NET WEIGHT AIR HANDLING SECTION	kg	352	439	504	584	656	761	905
NET WEIGHT SUPPLY FANS SECTION	kg	110	145	165	200	240	275	348
HYDRAULIC CONNECTIONS								
WATER INLET / OUTLET - ISO 7/1 - R	Ø	2"	2"	2" 1/2	2" 1/2	3"	3"	-
WATER INLET / OUTLET - DN - PN10 (5)	Ø mm	-	-	-	-	-	-	80
CONDENSATE DISCHARGE								
Rubber pipe - internal diameter	Ø mm	19	19	19	19	19	19	19

THE COOLING CAPACITY DOES NOT CONSIDER THE SUPPLY FAN MOTOR THERMAL LOAD

1. U = Under, downflow / O = Over, upflow
2. Gross value. Characteristics referred to entering air at 24°C-50%RH with chilled water temperature 7-12°C - 0% glycol. ESP=20Pa.
3. SHR = Sensible cooling capacity / Total cooling capacity.
4. Corresponding to the nominal external static pressure.
5. The counter-flange is not supplied. It is at Customer charge.

DUAL FLUID SYSTEM

DUAL FLUID system on the machine allows to obtain two independent cooling systems:

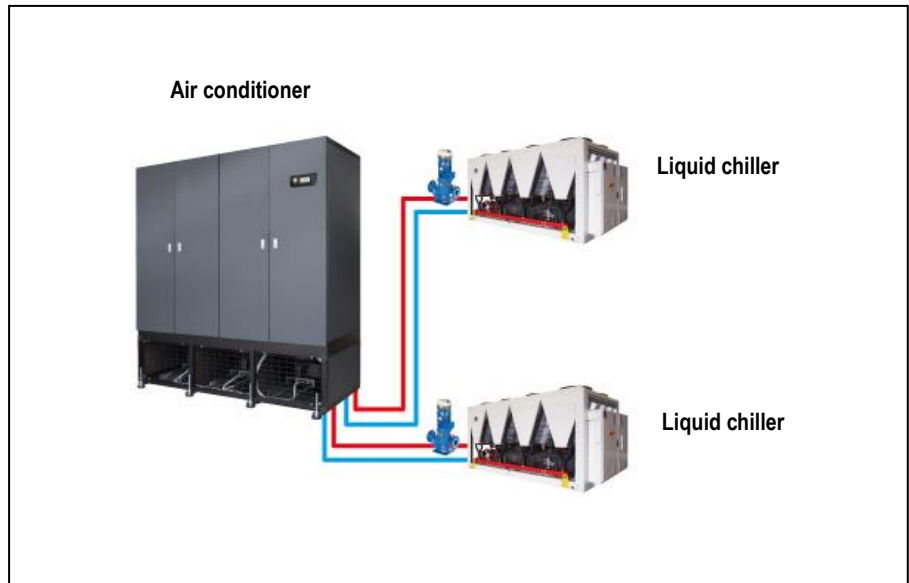

The microprocessor control system automatically manages the system, by activating the cooling circuit more convenient according to the parameters set.

With this system it is possible, with a limited use of space, to solve several plant problems such as:

- Chilled water coil fed with chilled water or mains water as a stand-by of the main cooling circuit.
- Double chilled water feeding with two independent circuit. This solution is used when you need to ensure redundancy of the cooling system.

The temperature control is performed with the same logic of the main coil.

TECHNICAL DATA

MODEL		065	088	096	127	148	173	226
SIZE		E4	E5	E6	E7	E8	E9	E10
VERSION (1)		U	U	U	U	U	U	U
COOLING CAPACITY (2)								
Total	kW	58,2	89,2	97,9	127	149	175	227
Sensible	kW	47,8	69,9	78,8	104	121	144	182
SHR (3)		0,82	0,78	0,80	0,82	0,81	0,82	0,80
COOLING COIL								
Water flow rate (2)	m ³ /h	10,00	15,37	16,80	21,90	25,74	30,13	39,24
dP coil + valve (2)	kPa	56	85,2	65,2	65,3	95,3	94,3	84,5
Water volume	l	17,6	23,1	27,1	31,4	36,4	43,2	53
HYDRAULIC CONNECTIONS								
WATER INLET / OUTLET - ISO 7/1 - R	Ø	2"	2"	2" 1/2	2" 1/2	3"	3"	-
WATER INLET / OUTLET - DN - PN10 (4)	Ø mm	-	-	-	-	-	-	80

THE COOLING CAPACITY DOES NOT CONSIDER THE SUPPLY FAN MOTOR THERMAL LOAD

1. U = Under, downflow / O = Over, upflow
2. Characteristics referred to entering air at 24°C-50%RH with chilled water temperature 7-12°C - 0% glycol. ESP=20Pa.
3. SHR = Sensible cooling capacity / Total cooling capacity.
4. The counter-flange is not supplied. It is at Customer charge.

HYDRAULIC DIAGRAM

Below hydraulic diagram referred to the standard configuration without optional.

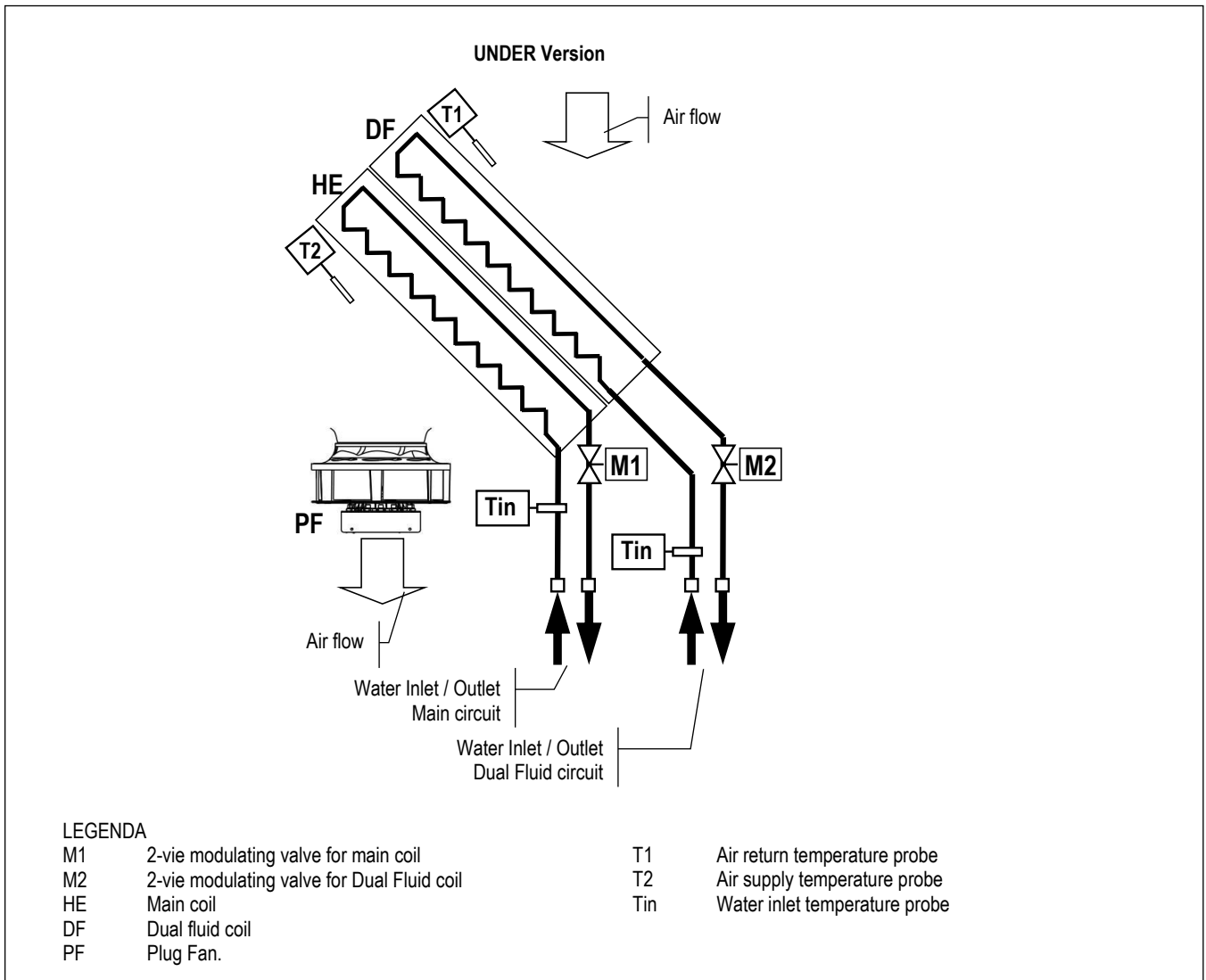

2-WAY VALVE FOR CHILLED WATER FLOW CONTROL (Main circuit and Dual Fluid circuit)



The water flow control in the finned coil is achieved through a **2-way modulating ball valve with equal percentage flow control** ensured by the integrated characterizing disc.

This type of valve offers the following series of benefits:

- Equal percentage flow control.
- Closing seal with leakage rate in Class A (EN 12266-1)
- No peaks initial flow.
- Excellent stability control thanks to the integrated characterizing disc.
- Closing pressure very high.
- Excellent characteristic in partialisation.
- Stability in control.
- Wide operating pressures which provide an optimal adjustment of the water flow even under extreme conditions.
- Maintenance free.
- Self-cleaning.

The rotative actuator is controlled by a signal 0 ... 10VDC from the microprocessor controller. The actuator is equipped with an emergency button for manual operation and is maintenance-free.

ACOUSTIC DATA

Acoustic data of the standard machine at full load working conditions.

WARNING:

In a closed room the noise produced by a sound source reaches the listener in two different ways:

- Directly
- Reflected from the surrounding walls, floor, ceiling, from furniture.

With the same sound source, the noise produced in a closed room is greater than that produced outdoors. In fact, the sound pressure level generated by the source, must be added to the one reflected from the room. Also, the shape of the room affects the sound.

MODEL		065	088	096	127	148	173	226
SIZE		E4	E5	E6	E7	E8	E9	E10
SOUND LEVEL (1)								
On air delivery Under	dB(A)	80,4	83,7	83,3	85,8	84,8	84,8	85,1
On air intake Under	dB(A)	67,8	69,5	70,7	71,5	72,2	72,2	72,4
On front side Under	dB(A)	58	60	61	62	63	63	63

1. Noise pressure level at 1 meter in free field – ISO 3744

ELECTRICAL DATA

MODEL		065	088	096	127	148	173	226
SIZE		E4	E5	E6	E7	E8	E9	E10
VERSION (1)								
Power supply		400/3+N/50	400/3+N/50	400/3+N/50	400/3+N/50	400/3+N/50	400/3+N/50	400/3+N/50
Maximum current input (FLA)	A	4,15	8,4	8,86	12,6	13,3	12,5	16,6

1. U = Under, downflow / O = Over, upflow

WATER QUALITY

For a correct and optimal functioning of the hydraulic circuits (chilled water and heating water), a water quality must be guaranteed as indicated in the table below.

The values shown in the table must be guaranteed during the entire life cycle of the machine.

	Description	Symbol	Range
1	Hydrogen ions	pH	7.5 ÷ 9
2	Presence of calcium (Ca) and magnesium (Mg)	Hardness	4 ÷ 8.5 °D
3	Chlorine ions	Cl ⁻	< 150 ppm
4	Iron ions	Fe ³⁺	< 0.5 ppm
5	Manganese ions	Mn ²⁺	< 0.05 ppm
6	Carbon dioxide	CO ₂	< 10 ppm
7	Hydrogen sulphide	H ₂ S	< 50 ppb
8	Oxygen	O ₂	< 0.1 ppm
9	Chlorine	Cl ₂	< 0.5 ppm
10	Ammonia	NH ₃	< 0.5 ppm
11	Ratio between carbonates and sulphates	HCO ₃ ⁻ /SO ₄ ²⁻	> 1
12	Sulphate ions	SO ₄ ⁻	< 100 ppm
13	Phosphate ions	PO ₄ ³⁻	< 2.0 ppm

where: $1/1.78^{\circ}D = 1^{\circ}Fr$ with $1^{\circ}Fr = 10 \text{ gr CaCO}_3 / \text{m}^3$

ppm = parts for millions

ppb = part for billion

Explanatory notes:

- ref.1: A greater concentration of hydrogen ions (pH) than 9 implies a high risk of deposits, whereas a lower pH than 7 implies a high risk of corrosion.
- ref.2: The hardness measures the amount of Ca and Mg carbonate dissolved in the water with a temperature lower than 100°C (temporary hardness). A high hardness implies a high risk of deposits.
- ref.3: The concentration of chloride ions with higher values than those indicated causes corrosion.
- ref. 4 - 5 - 8: The presence of iron and manganese ions and oxygen leads to corrosion.
- ref.6 - 7: Carbon dioxide and hydrogen sulphide are impurities that promote corrosion.
- ref.9: Usually in water from the waterworks it is a value of between 0.2 and 0.3 ppm. High values cause corrosion.
- ref.10: The presence of ammonia reinforces the oxidising power of oxygen
- ref.11: Below the value shown in the table, there is a risk of corrosion due to the trigger of galvanic currents between copper and other less noble metals.
- ref.12: The presence of sulphates ions triggers corrosion phenomenon.
- ref.13: The presence of phosphates ions triggers corrosion phenomenon.

It is necessary to carry out periodic checks, with withdrawals at different points of the hydraulic system.

During the first year of operation, checks are recommended every 4 months which can be reduced every 6 months starting from the second year of operation.

WARNING:

It is necessary that, in the presence of dirty and / or aggressive waters, an intermediate heat exchanger is installed upstream of the heat exchangers

MICROPROCESSOR CONTROL SYSTEM



The microprocessor control system is equipped with 6 keys terminal and back lighted graphic display on which all information in different languages or easily identifiable symbols are displayed. The system disposes of a “flash” memory that preserves the information even in absence of power supply. Part of memory is dedicated to the registration of intervened events - up to 200 events.

KEYBOARD FUNCTIONS

	ALARM	Alarm, Back-red light active – alarm presence, push to have alarm description. If more than one alarm(s), the others can be scrolled by Key UP / DOWN
	PRG	Menu list, scrolled by key UP/DOWN: Unit; Set-point; In/Out; Clock; History; User; Service; Factory. Use the ENTER key to execute the mode.
	ESC	Home. Used to come back to the previous menu level or to the main screen.
	UP DOWN	Used to change the pages and values of sets. When display is in main screen (HOME), pressing one of them (UP/DOWN) will display the synoptic of the main controls.
	ENTER	Moving the cursor on adjustable Program(s) fields, to confirm the changes, press the key (ENTER) to get out of the fields.

CONNECTIVITY

Through the optional serial port, the microprocessor control enables communication with the modern buildings BMS systems with the following protocols:

- MBUS/JBUS (RS485) serial card;
- MBUS/JBUS (RS232) for GSM modem serial card;
- LON Works serial card;
- BACnet per Ethernet – SNMP – TCP/IP serial card;
- BACnet per MS/TP serial card;

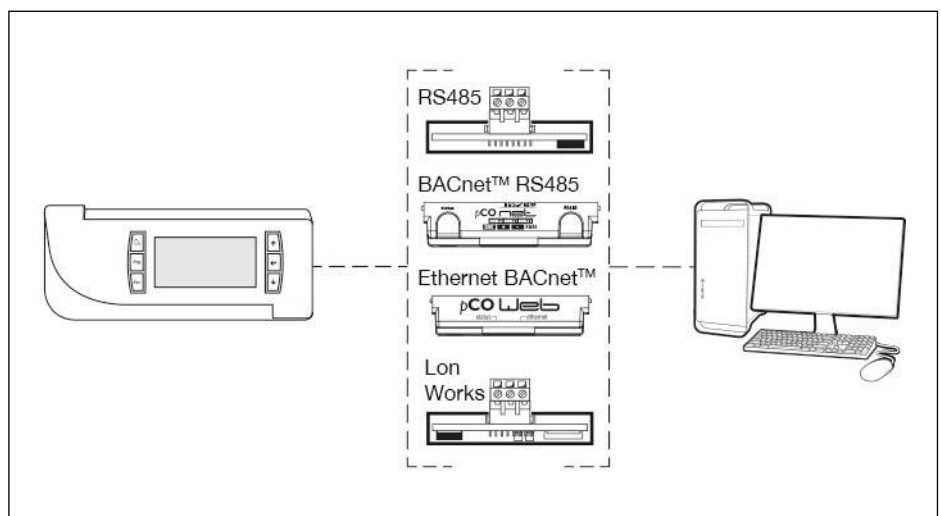

PASSWORD

- Level 1: On request of the End User. Allowing to reach USER menu
- Level 2: Asks to Service: Allowing to reach SERVICE menu
- Level 3: Asks to Service: Allowing to reach FACTORY menu

No passwords request to enter: UNIT, SETPOINT, IN/OUT, CLOCK, HISTORY menu

LAN NETWORK

The LAN is part of the control software and it is possible to connect up to 10 units.
This type of connection allows to control the units in coherent way, moreover the units can be controlled and managed from a shared remote terminal.
Electrical connections are on electrical panel connecting terminals.

LAN ADDRESS LIST

Unit #	1	2	3	4	5	6	7	8	9	10	Remote Terminal
Mother board address	1	2	3	4	5	6	7	8	9	10	--
Terminal address	11	12	13	14	15	16	17	18	19	20	32

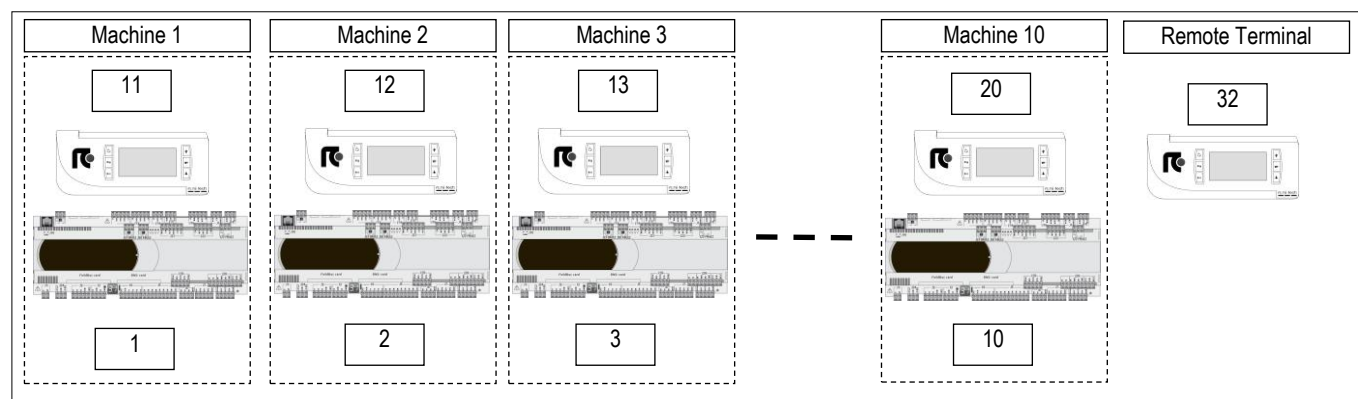

The unit connection to the local network (LAN) allows to perform the following functions:

- Balancing the operating hours among the different units by rotating the reserve units (Stand-by)
- Turning on the reserve units in case other units should turn off due to an alarm, maintenance or power feed interruption
- Turning on reserve units to offset the excessive thermal load
- Checking up to 10 units with a single user terminal (shared user terminal)

DEMAND LIMIT

Demand Limit function is part of the control software for machines. It allows to limit the absorbed current of the machine.

The function must be activated and configured. A digital inlet on electrical panel connecting terminals allows the remote enabling of the function with an external signal without tension. The software allows to select the resources to disable (compressors, electric heaters,...).

OPTIONAL ACCESSORIES – DOUBLE POWER SUPPLY WITH AUTOMATIC TRANSFER SWITCH



The optional is not compatible with “oversized electric heaters” and “oversized humidifier” optional accessories.

The motorised changeover switches automatically manage changeover under load between two three-phase power supplies, or manually for emergency operations.

These transfer switching (TSE) devices are suitable for low voltage systems with interruption of the supply to the load during transfer.

The model supplied in the automatic version checks the source and switches over automatically, based on configurable parameters.

OPEN TRANSITION TYPE TRANSFER SWITCH WITH A MINIMUM INTERRUPTION OF THE SUPPLY DURING TRANSFER.

To maintain the microprocessor powered and avoid its restarts is mandatory to foresee the installation of the “temporary microprocessor power supply” optional accessory. The system guarantees the microprocessor power supply for a few minutes, in case of supply voltage failure.

The remote condenser must be powered by the automatic transfer switch. The installation of “Electrical power supply for remote condenser from the indoor machine electrical board” optional accessory is requested.

ATS INSTALLATION

Frame	Power Supply	ATS Installation
E4	400/3+N/50	EXTERNAL, supplied in kit
E5	400/3+N/50	INTERNAL (on unit electrical panel)
E6	400/3+N/50	INTERNAL (on unit electrical panel)
E7	400/3+N/50	INTERNAL (on unit electrical panel)
E8	400/3+N/50	INTERNAL (on unit electrical panel)
E9	400/3+N/50	INTERNAL (on unit electrical panel)
E10	400/3+N/50	INTERNAL (on unit electrical panel)

For EXTERNAL installation, ATS is supplied in special box with IP 3X ingress protection, with the dimensions shown in the figure below.

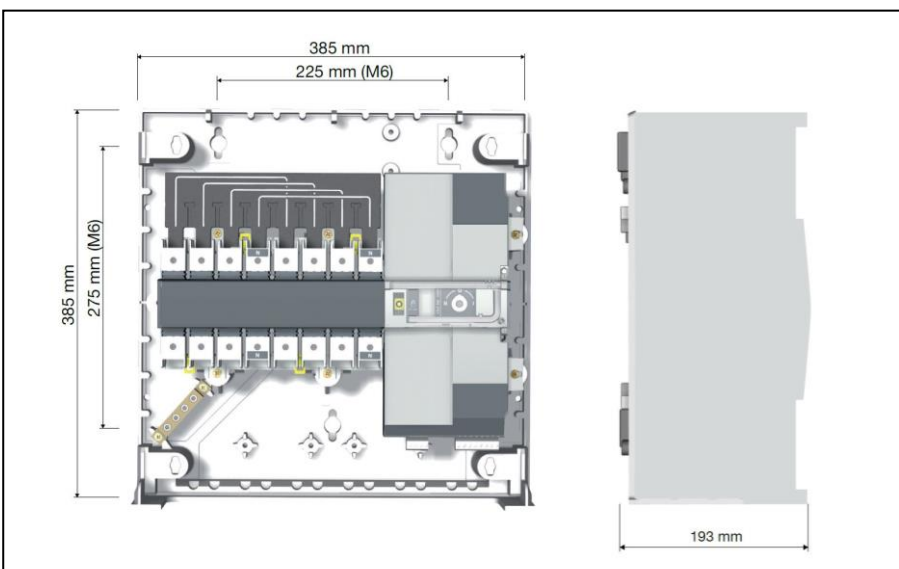

OPTIONAL ACCESSORIES – NETWORK ANALYZER



The optional is installed within the electrical box downstream the main switch with door safety lock:

- Network transducer;
- Current transformers, one for each power supply phase cable.

This device provides continuous measurement of power consumption, monitoring current, voltage and power. These values are sent to unit microprocessor via RS485 serial cable, as shown on the unit wiring diagram.

The displayed variables are:

- Phase to phase voltage, only for three-phase units;
- Phase voltage (phase-neutral);
- Phase current;
- Neutral current only for three-phase units;
- Active phase power, only for three-phase units;
- Total active power;
- Active energy;
- Hour counts

OPTIONAL ACCESSORIES – FIRE / SMOKE SENSORS

Is possible to install one or both of the following sensors. Sensors are supplied in mounting kit. Installation within the room at customer care.



SMOKE DETECTOR

The optical smoke detector senses the presence of combustion by-products (visible smoke) and activates an alarm.

The operating principle is based on the light scattering technique (Tyndall effect).

The device is in conformity to EN 54-7 standard.

Technical features:

Material	ABS
Power supply	12...28 Vdc
Normal current	50µA a 24 Vdc
Alarm current	25mA a 24 Vdc
LED visibility	360° (double led)
Storage temperature	-10...+70°C
Operating temperature	-10...+70°C
Max. speed air	0,2 m/s
Relative humidity	<93% not-condensing
Index of protection	IP 20
Testing by magnet	Yes
Relay	max. 1A 30Vdc
Signal repeater	14mA a 24 Vdc
Sensor coverage:	40m ² max
Shielded connection cable	sez. min 0,5 mm ²
Colour	White



HEAT DETECTOR

The heat detector has been designed to identify temperatures at which fires may start. When the temperature exceeds the set threshold or when there is a rapid variation in temperature, the relay is activated to signal an alarm.

The device is in conformity to EN 54-5 standard.

Technical features:

Material	ABS
Power supply	12...28 Vdc
Normal current	50µA a 24 Vdc
Alarm current	25mA a 24 Vdc
LED visibility	360° (double LED)
Storage temperature	-10...+70°C
Operating temperature	-10...+70°C
Relative humidity	<93% non-condensing
Index of protection	IP 20
Testing by magnet	Yes
Relay	max. 1A 30Vdc
Signal repeater	14mA a 24 Vdc
Alarm temperature threshold	62°C
Sensor coverage:	40m ² max
Shielded connection cable	min 0.5 mm ²
Colour	White

OPTIONAL ACCESSORIES - CONDENSATE DISCHARGE PUMP



A plastic case contains the vertical type pump, the water tank with float plus safety switch and hydraulic and electric connection.

Together the pump 10 linear meters anti-crushing plastic discharge spiral tube is supplied

The optional must be installed as shown in the documentation delivered together with the unit.

Wiring includes power supply and an alarm, displayed on microprocessor, that includes motor pump thermal protection and tank overflow.

The condensate discharge pump operation is fully automatic.

WARNING

For all the machines the optional accessory is supplied in mounting kit.

TECHNICAL DATA

Power supply: 230V~ 50Hz

Electrical data: 70W – 0,67A

Maximum water flow: 500 l/h

Maximum delivery height: 5.0 m

Sound level: 45dBA a 1 m

Maximum water temperature: 70°C

Water acidity: pH>2.5

Tray volume: 2.0 l

Protection IP 20

CONDENSATE DISCHARGE PUMP

(Dimensions in millimetres)

OPERATING DATA

Discharge head	Total length of discharge pipes (Ø 10 mm internal)			
	5m	10m	20m	30m
1m	380	300	240	190
2m	310	260	200	150
3m	240	200	145	110
4m	150	130	80	60
5m	30	20	0	0

OPTIONAL ACCESSORIES – MODULATING STEAM HUMIDIFIER



The optional includes the combined temperature / humidity sensor on unit air intake.

The accessory is factory installed and requires water filling connection.

Humidifier water charge and discharge pipes are not supplied.

It is recommended to install a filter and a shut-off valve on the pipe to the water inlet.

This humidifier produces non-pressurized steam by electrodes immersed in the water inside the cylinder: they bring the electric phase in the water that works as an electrical resistance and overheats. The steam so produced is distributed with dedicated distributors and used for ambient humidification or for industrial processes.

CHARACTERISTICS OF THE SUPPLY WATER

The quality of the used water influences the evaporation process, so the humidifier can be fed with **not-treated water, only when potable and non-demineralised.**

LIMIT VALUES

		Min	Max
Hydrogen ions	pH	7	8,5
Specific conductivity at 20°C	$\sigma_{R, 20^\circ C}$ $\mu S/cm$	300	1250
Total dissolved solids	TDS mg/l	(1)	(1)
Dry residue at 180°C	R ₁₈₀ mg/l	(1)	(1)
Total hardness	TH mg/l CaCO ₃	100 (2)	400
Temporary hardness	mg/l CaCO ₃	60 (3)	300
Iron + Manganese	mg/l Fe + Mn	0	0,2
Chlorides	ppm Cl	0	30
Silica	mg/l SiO ₂	0	20
Residual chlorine	mg/l Cl ⁻	0	0,2
Calcium sulphate	mg/l CaSO ₄	0	100
Metallic impurities	mg/l	0	0
Solvents, diluents, soaps, lubricants	mg/l	0	0

(1) Values depending on specific conductivity; in general: TDS \cong 0,93 * $\sigma_{R, 20^\circ C}$; R₁₈₀ \cong 0,65 * $\sigma_{R, 20^\circ C}$

(2) Not lower than 200% of the chloride content in mg/l di Cl⁻

(3) Not lower than 300% of the chloride content in mg/l di Cl⁻

WARNING:

- No relation can be demonstrated between water hardness and conductivity.
- **Do not treat water with softeners!** This could cause corrosion of the electrodes or the formation of foam, leading to potential operating problems or failures.
- Do not add disinfectants or corrosion inhibitors to water, as these substances are potentially irritant.
- Is absolutely forbidden to use well water, industrial water or water drawn from cooling circuits; in general, avoid using potentially contaminated water, either from a chemical or bacteriological point of view

TECHNICAL DATA

MODEL		065	088	096	127	148	173	226
SIZE		E4	E5	E6	E7	E8	E9	E10
VERSION (1)		U	U	U	U	U	U	U
VAPOUR PRODUCTION	kg/h	8,0	8,0	8,0	15,0	15,0	15,0	15,0
Power input	kW	6	6	6	11,3	11,3	11,3	11,3
Absorbed current (OA)	A	8,7	8,7	8,7	16,2	16,2	16,2	16,2
Max absorbed current (FLA)	A	12,4	12,4	12,4	23	23	23	23
Water content	l	6,4	6,4	6,4	10,3	10,3	10,3	10,3
Max water supply pressure	Bar	1÷8	1÷8	1÷8	1÷8	1÷8	1÷8	1÷8
NET WEIGHT (2)	kg	14	14	14	20	20	20	20
HYDRAULIC CONNECTION								
WATER INLET - ISO 228/1 – G M	Ø	3/4"	3/4"	3/4"	3/4"	3/4"	3/4"	3/4"
WATER OUTLET - external diameter	Ø mm	19	19	19	19	19	19	19

1. U = Under, downflow / O = Over, upflow

2. Value to be added to the weight of the standard unit. Does not include the weight of the water content.



HUMIDIFIER OVERSIZED

The optional is not available for sizes E7, E8, E9, E10.
On request it is possible to install the oversized humidifiers.
The components are the same standard accessory

TECHNICAL DATA

MODEL		065	088	096	127	148	173	226
SIZE		E4	E5	E6	E7	E8	E9	E10
VERSION (1)		U	U	U	U	U	U	U
VAPOUR PRODUCTION	kg/h	15	15	15	--	--	--	--
Power input	kW	11,3	11,3	11,3	--	--	--	--
Absorbed current (OA)	A	16,2	16,2	16,2	--	--	--	--
Max absorbed current (FLA)	A	23	23	23	--	--	--	--
Water content	l	10,3	10,3	10,3	--	--	--	--
Max water supply pressure	Bar	1÷8	1÷8	1÷8	--	--	--	--
NET WEIGHT (2)	kg	20	20	20	--	--	--	--
HYDRAULIC CONNECTION								
WATER INLET - ISO 228/1 – G M	Ø	3/4"	3/4"	3/4"	--	--	--	--
WATER OUTLET - external diameter	Ø mm	19	19	19	--	--	--	--

1. U = Under, downflow / O = Over, upflow
2. Value to be added to the weight of the standard unit. Does not include the weight of the water content.

OPTIONAL ACCESSORIES – DEHUMIDIFICATION SYSTEM

Components:

- Temperature / Humidity sensor on the air intake.
- Temperature sensor on cooling coil water inlet / outlet.
- Electronic control system of the dew point temperature for the combined intervention of cooling capacity and air flow.

OPTIONAL ACCESSORIES – ELECTRIC HEATERS



Electric heater consisting of finned aluminum elements, ensuring low surface temperature and deleting the air ionization problems. The optional is installed downstream the main cooling coil.

In electric heaters with three working steps the activation is binary type.

Components:

- Electric heater in aluminium armoured elements with integral fins
- Electrical control
- Safety thermostat.

TECHNICAL DATA

MODEL		065	088	096	127	148	173	226
SIZE		E4	E5	E6	E7	E8	E9	E10
VERSION (1)		U	U	U	U	U	U	U
THERMAL CAPACITY	kW	9,0	13,5	13,5	18,0	18,0	27,0	27,0
Absorbed current (OA)	A	13,0	19,5	19,5	26,0	26,0	39,0	39,0
First working step	kW	3,0	4,5	4,5	4,5	4,5	9	9
Second working step	kW	6,0	9,0	9,0	13,5	13,5	18	18
Third working step	kW	3,0+6,0	4,5+9,0	4,5+9,0	4,5+13,5	4,5+13,5	9,0+18,0	9,0+18,0
NET WEIGHT (2)	kg	9	9	9	10,5	10,5	18,5	18,5

OVERSIZED ELECTRIC HEATERS

On request it is possible to install the oversized electric heating system.

The components are the same standard accessory

TECHNICAL DATA

MODEL		065	088	096	127	148	173	226
SIZE		E4	E5	E6	E7	E8	E9	E10
VERSION (1)		U	U	U	U	U	U	U
THERMAL CAPACITY	kW	13,5	18,0	18,0	27,0	27,0	36,0	36,0
Absorbed current (OA)	A	20	26	26	39	39	52	52
First working step	kW	4,5	4,5	4,5	9	9	13,5	13,5
Second working step	kW	9,0	13,5	13,5	18	18	22,5	22,5
Third working step	kW	4,5+9,0	4,5+13,5	4,5+13,5	9,0+18,0	9,0+18,0	13,5+22,5	13,5+22,5
NET WEIGHT (2)	kg	9	10,5	10,5	14,5	14,5	22,5	22,5

1. U = Under, downflow / O = Over, upflow
2. Value to be added to the weight of the standard unit.

OPTIONAL ACCESSORIES – 2-WAY BY-PASS VALVE FOR MAIN CHILLED WATER CIRCUIT



2-way motorized valve with 0-10 VDC control actuator and emergency manual control for the third way (by-pass) of the hydraulic circuit.
 The valve is in combination with the main 2-way water flow control valve.
 The by-pass valve can be installed on the main circuit.
 The optional accessory is factory installed and don't modify the overall dimensions of the unit.

The coupling to the main 2-way control valve of a second modulating valve, connected in by-pass, allows to obtain the same control system of a 3-way mixing valve for plant with constant water flow.
 At the same time the appropriate sizing of these valves allows hydraulic balancing of the by-pass way.

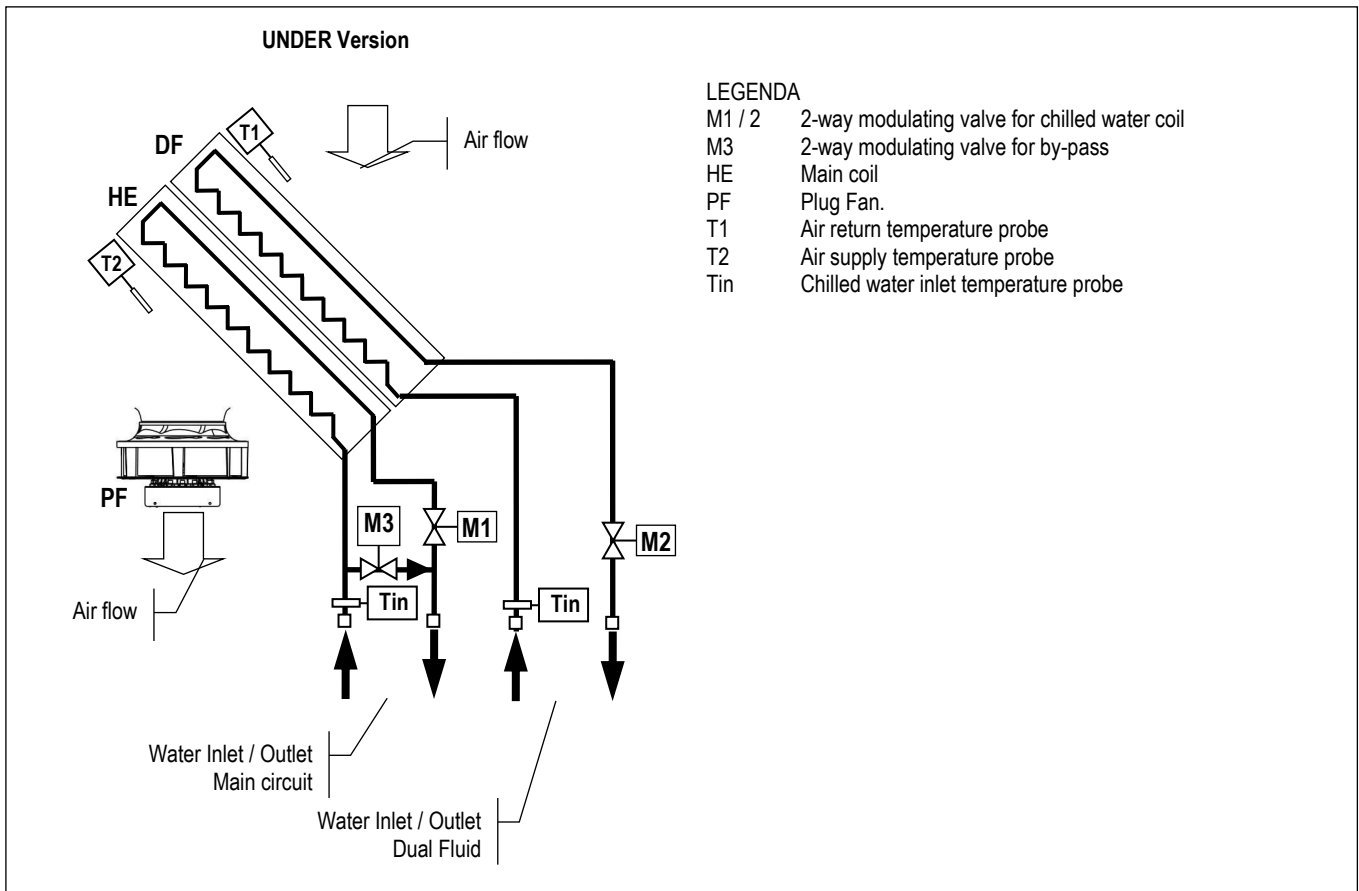

TECHNICAL DATA

MODEL	065	088	096	127	148	173	226
SIZE	E4	E5	E6	E7	E8	E9	E10
VERSION (1)	U	U	U	U	U	U	U
2-WAY VALVE FOR BY-PASS							
k_v – Flow coefficient	m^3/h	6,3	16,0	16,0	25,0	25,0	40,0

1. U = Under, downflow / O = Over, upflow

IMPORTANT

For further information, please refer to chapter “VALVE PRESSURE DROP CALCULATION AS FUNCTION OF WATER FLOW RATE”



OPTIONAL ACCESSORIES - DOUBLE PANELS IN EUROCLASS A1

The optional is designed to supply the panels only in Euroclass A1 of reaction to fire, furthermore allows a noise insulation of the panels of the air conditioners.

The pressure level reduction of the unit is about 2 dB(A). The reduction refers ONLY to the sound level radiated from the unit or in front of the unit. The noise level data on return and delivery air do not undergo reductions.

The accessory includes:

- External part as standard panel.
- Internal part in galvanized steel sheet.
- The inside noise insulation with special soundproof material.

REACTION TO FIRE CLASSIFICATION

On Italian territory, the classification is per the D.M. of June 26, 1984 and subsequent amendments, providing for a sort in "Classes" from 0 (non-combustible material) to 5 (extremely flammable material). In Europe, the classification is regulated per UNI EN 13501-1: 2009 ordered to "Euro-classes", from A1 (non-combustible material) to F (highly flammable material).

A comparison of the Italian and European classes is not possible because the methods and evaluation criteria are completely different. The comparison table below is being considered purely indicative.

Definition	Italian classes	Euro-classes
Non-combustible material	Class 0	A1
Combustible material, very limited contribution to fire	Class 1	A2 – B
Combustible material, limited contribution to fire	Class 2	A2 – B - C
Combustible material, medium contribution to fire	Class 3	C – D
Combustible material, highly contribution to fire	Class 4	E
Combustible material, easily flammable	Class 5	F

Is possible to provide the sandwich panels for the OVER units with air flow from the top. This implies that the air intake must necessarily be from the base of the unit with front blind paneling.

SIZE		E4	E5	E6	E7	E8	E9	E10
VERSION (1)		U	U	U	U	U	U	U
Weight increasing (2)	kg	70	86	110	130	145	165	195

1. U = Under, downflow / O = Over, upflow
2. Add this value to the total unit weight

OPTIONAL ACCESSORIES – ePM₁₀ 50% EFFICIENCY AIR FILTERS

The ePM₁₀ 50% air filters (according to ISO EN 16890), replace the standard one. The filters generate a pressure drops higher than the standard ones. The filters are made of glass micro-fibre and are not regenerable.

MODEL		065	088	096	127	148	173	226
SIZE		E4	E5	E6	E7	E8	E9	E10
VERSION (1)		U	U	U	U	U	U	U
Additional pressure drops (2)	Pa	50	58	59	73	71	72	51

1. U = Under, downflow / O = Over, upflow
2. Additional pressure drops referred to nominal air flow and clean filter.

OPTIONAL ACCESSORIES – NON RETURN MOTORIZED DAMPER

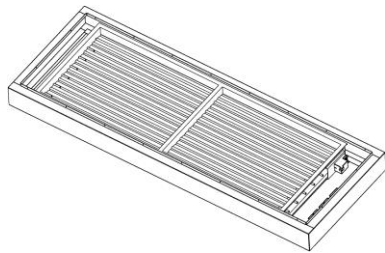

Accessory installed on units air return and it can be matched to plenums and floor stand.

FRAMEWORK

- Frame in galvanized steel sheet with protective surfaces treatment in compliance with UNI ISO 9227/ASTMB117 and ISO 7253, and painted with epoxy powders. Colour RAL 9005;
- Opposed blade dampers in galvanized steel sheet.
- Actuator for damper control.
- Terminals for electric connection to the unit.

For a correct installation we suggest you to utilize a gasket between the damper and the unit or the plenum or the floor stand.

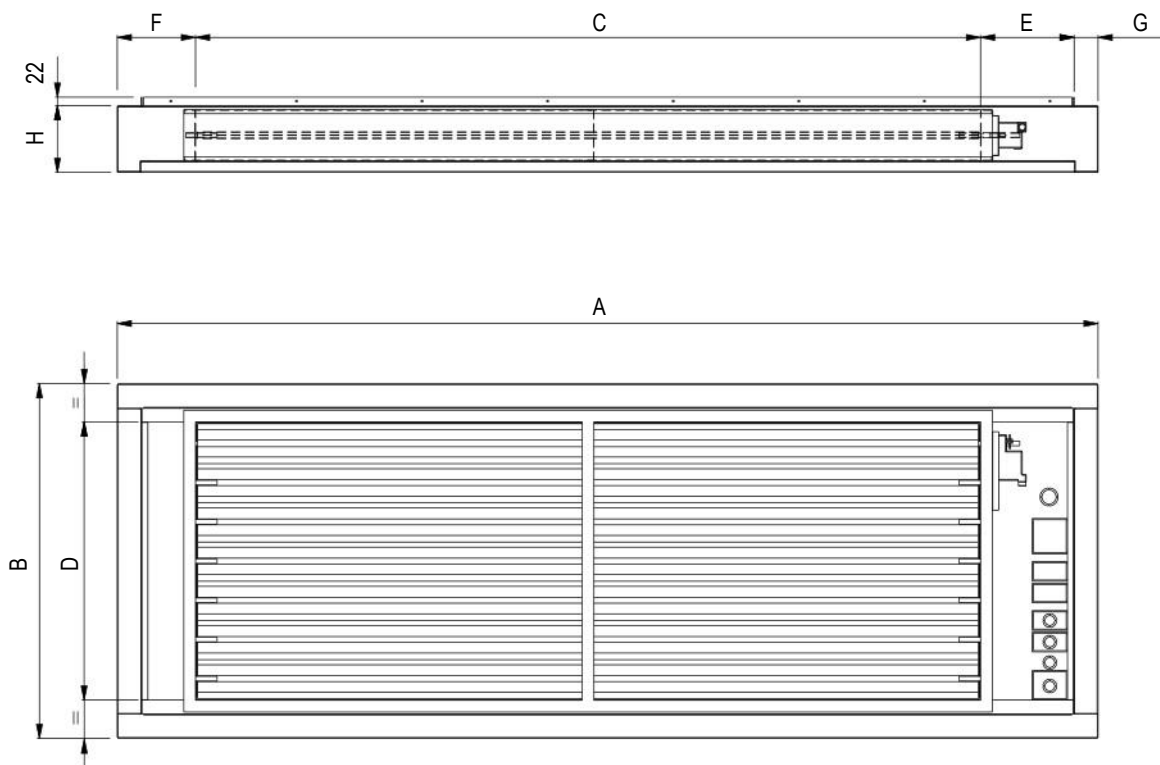

SIZE		E4	E5	E6	E7	E8	E9	E10
VERSION (1)		U	U	U	U	U	U	U
A	mm	1305	1630	1873	2175	2499	2899	3510
B	mm	905	905	905	905	905	905	905
C	mm	900	1250	1500	1750	2000	2300	2800
D	mm	710	710	710	710	710	710	710
E	mm	142	204	250,5	226,5	238,5	288,5	294
F	mm	202	115	61,5	137,5	199,5	249,5	355
G	mm	61	61	61	61	61	61	61
H	mm	170	170	170	170	170	170	170
Weight (2)	kg	40	50	58	65	75	90	115

1. U = Under, downflow / O = Over, upflow
2. Add this value to the total unit weight

INSTALLATION EXAMPLE

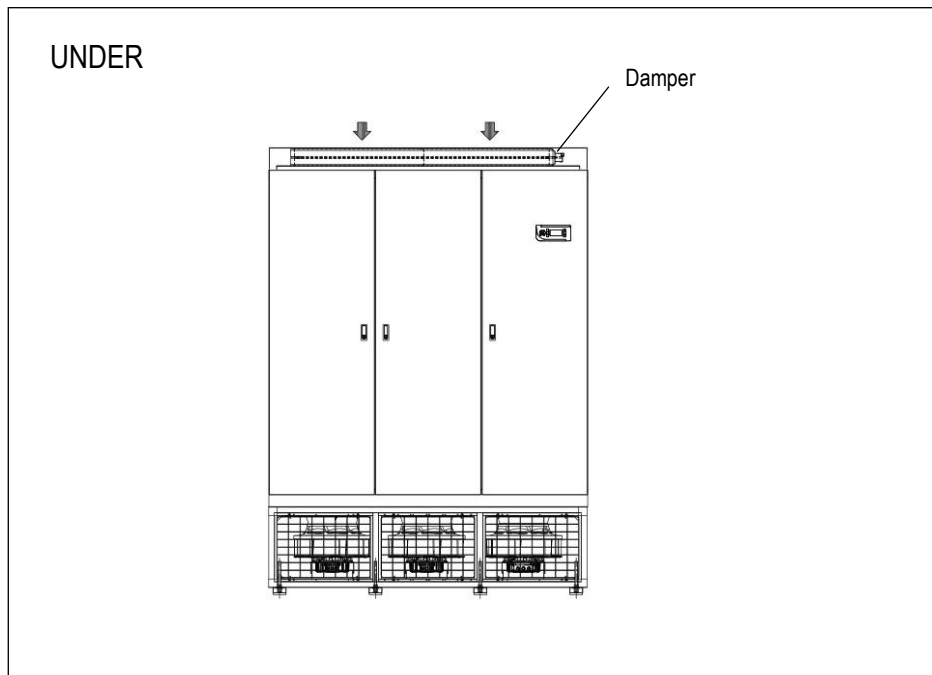

WORKING LOGIC

The damper opens at supply fans activation to allow air flow.

When the fans stop for failure or stop command, the damper closes, preventing air flow into the unit.

OPTIONAL ACCESSORIES - PLENUM ON AIR RETURN

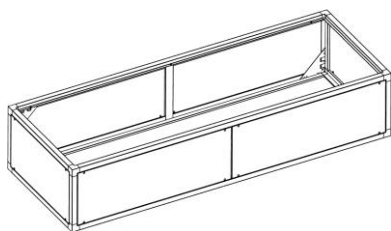

The optional is supplied separately and the installation on the unit is at Customer care.
The plenums can be used on return air.
The plenums have same technical characteristics and dimensions of the machine cabinet.

It is possible to install only a single plenum to ensure stability to the unit.

FRAMEWORK

- Frame in aluminium extrusion, painted with epoxy powders. Colour RAL 9005;
- Panels in galvanized steel sheet with protective surfaces treatment in compliance with UNI ISO 9227/ASTMB117 and ISO 7253, and painted with epoxy powders. Colour RAL 9005;
- Panels insulated with polyurethane foam and seals to ensure air tight.
- Panels fixed with screws.
- Removable panels.
- Set of fixing elements to fasten the plenum to the unit.

WARNING

**In UNDER version units the hydraulic piping is inside the machine.
The air delivery plenums sometime don't allow the extension of the pipes downwards.
In special cases, to keep the connections inside the machine, foresee a plenum 200mm higher than the standard one.**

EMPTY PLENUM

The plenum is void and can be used to rise the return air inlet.
Remove the frontal panels for inspection.

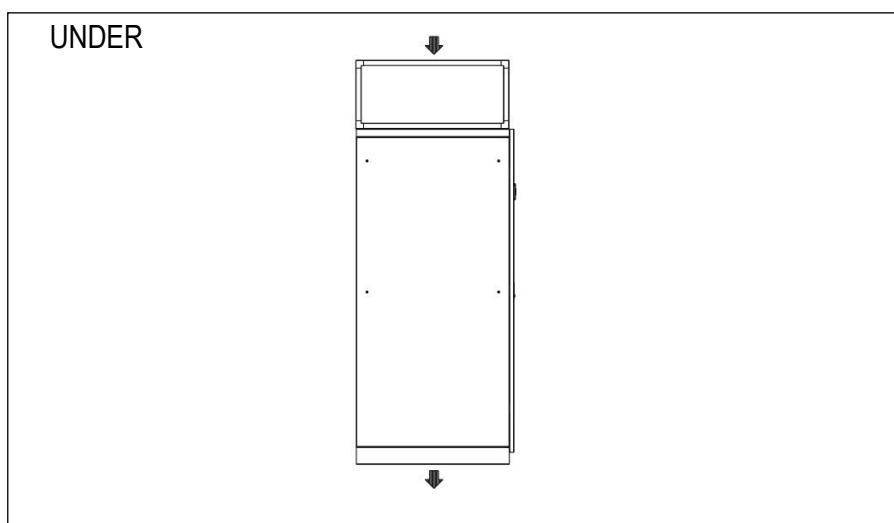

SIZE		E4	E5	E6	E7	E8	E9	E10
VERSION (1)		U	U	U	U	U	U	U
A	mm	510	510	510	510	510	510	510
Weight (2)	kg	30	40	45	50	60	70	78

EMPTY PLENUM REACTION TO FIRE – EUROCLASS A1

SIZE		E4	E5	E6	E7	E8	E9	E10
VERSION (1)		U	U	U	U	U	U	U
A	mm	510	510	510	510	510	510	510
Weight (2)	kg	39	50	56	62	74	85	96

1. U = Under, downflow / O = Over, upflow
2. Add this value to the total unit weight

OPTIONAL ACCESSORIES – DIRECT FREE-COOLING PLENUM

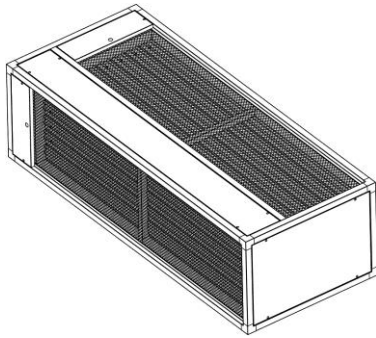

The optional is supplied separately and the installation on the unit is at Customer care.
The plenums have same technical characteristics and base dimensions of the machine cabinet.
The optional allow to obtain free-cooling by direct ambient air intake into the room.
The dampers are proportionally managed by the microprocessor control, that regulates the quantity of the ambient air to put in the room according to the set-point.

COMPONENTS

- Frame in aluminium extrusion, painted with epoxy powders. Colour RAL 9005;
- Panels in galvanized steel sheet with protective surfaces treatment in compliance with UNI ISO 9227/ASTMB117 and ISO 7253, and painted with epoxy powders. Colour RAL 9005;
- Panels insulated with polyurethane foam and seals to ensure air tight.
- Panels fixed with screws.
- Removable panels.
- Opposed blade dampers in galvanized steel sheet and safety grille for ambient air and room air suction.
- Actuator for each damper.
- Terminals for electric connection to the unit.
- Combined Temperature / Humidity sensor on machine air suction. The sensor must be moved outside the air conditioners for a proper read of the room temperature value.
- Temperature sensor for outdoor air. The sensor must be installed in the outdoor air suction duct or anyway protected against atmospheric agent.
- Free contact for free-cooling operating status monitoring.
- Set of fixing elements to fasten the plenum to the unit.

For a correct installation use a gasket between the plenum and the unit.

WARNING

IT IS COMPULSORY TO INSTALL INTO THE ROOM AN APPROPRIATELY SIZED OVERPRESSURE DAMPER TO ALLOW THE ROOM AIR EXHAUSTION DURING FREE-COOLING WORKING MODE.

ESEMPIO DI INSTALLAZIONE

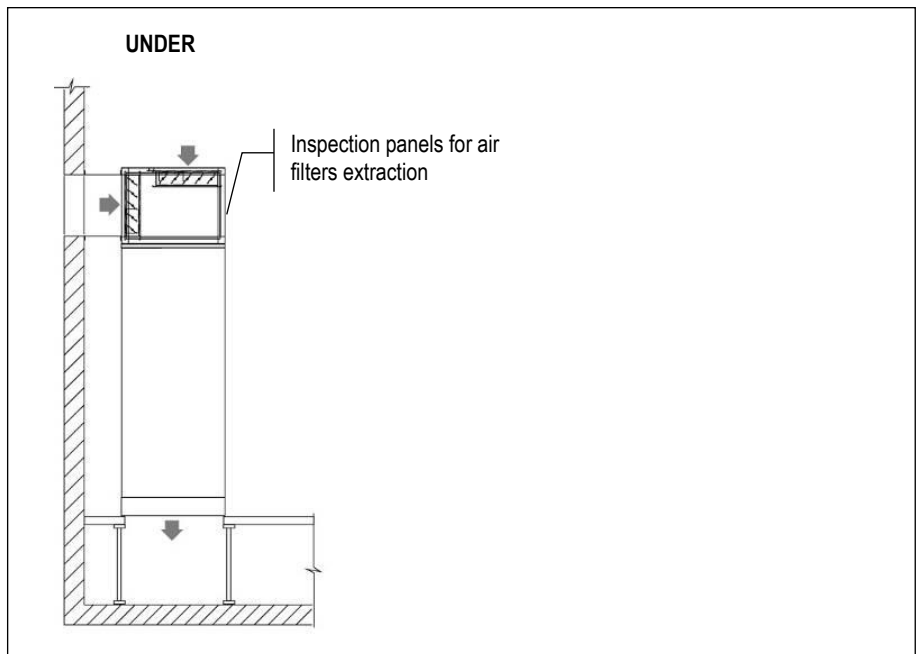

Ducting are at Customer care.
We suggest you to install a rain-proof grille on ambient air intake.

UNDER VERSION

SIZE E4 / E5

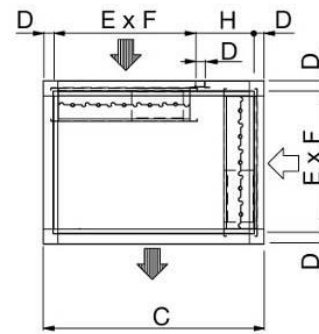
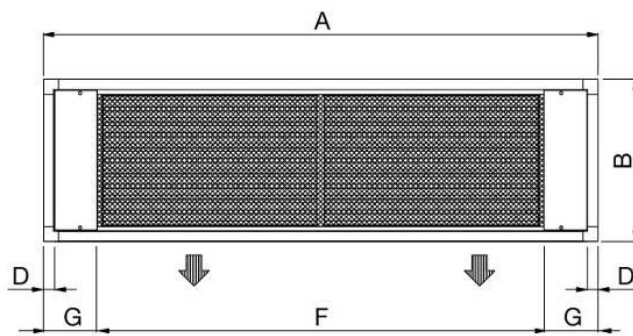

SIZE E6 / E7 / E8 / E9 / E10

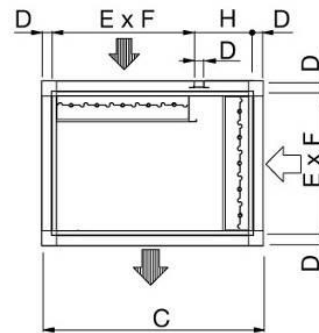
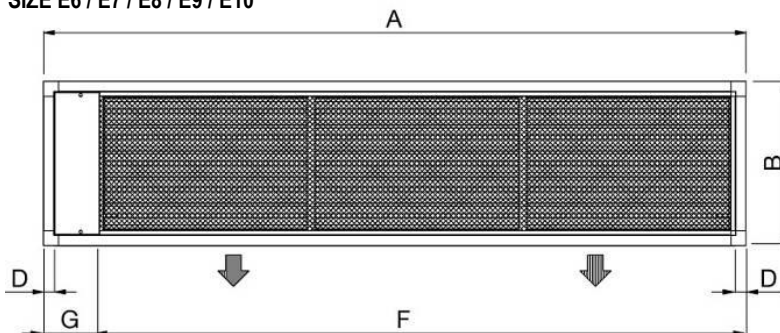

SIZE		E4	E5	E6	E7	E8	E9	E10
VERSION (1)		U	U	U	U	U	U	U
A	mm	1305	1630	1873	2175	2499	2899	3510
B	mm	630	630	630	630	630	630	630
C	mm	905	905	905	905	905	905	905
D	mm	40	40	40	40	40	40	40
E	mm	550	550	550	550	550	550	550
F	mm	1035	1335	1664	1965	2220	2670	3135
G	mm	135	147,5	209	210	279	229	375
H	mm	275	275	275	275	275	275	275
Weight (2)	kg	53	61	78	90	110	130	155

1. U = Under, downflow / O = Over, upflow
2. Add this value to the total unit weight

OPTIONAL ACCESSORIES – COOLNET



COOLNET: Intelligent NET for IT Cooling that maximizes the energy saving in LOAD SHARING

MAIN FEATURES

COOLNET is a software that applies to chilled water air conditioners microprocessor control system. It optimizes the LOAD SHARING working mode and maximizes the energy savings.

OPTIONAL ACCESSORIES – ADAPTIVE SET-POINT



ADAPTIVE SET-POINT

An advanced algorithm that instantaneously detects the real thermal load of the indoor units and then conveys this information to the outdoor chillers, strongly increasing their operation.

- Dynamic variation of the chillers set point and water flow.
- Increasing of the free cooling mode.
- Adoption of the active redundancy system to better exploit stand-by chillers.

DATA CENTER MANAGER (Optional accessory)

DATA CENTER MANAGER is a centralized management system that ensures a smart communication between indoor chilled water units and the outdoor chillers.

The device manages the outdoor units according to the inlet and outlet temperature registered by the probes and by request of the indoor unit.

OPTIONAL ACCESSORIES – KIPlink – Keyboard in your Pocket



KIPlink - Keyboard In Your Pocket - is the innovative user interface based on WiFi technology that allows one to operate on the unit directly from the smartphone or tablet. Using KIPlink, it is possible to turn the unit on and off, adjust the set-point, plot the main operating variables, monitor in detail the status of the refrigerant circuits, the compressors, the fans and display and reset the possible alarms.

Scan the QR code on the electrical board of the unit to have access to the unit control through web browser web or App. The access is possible within the local WiFi network.

KIPlink hardware:

- Wi-Fi antenna in the electrical board;
- ON/OFF button with power LED and Unit status LED. Provided when the unit is equipped with KIPlink and without 6-keys keyboard (optional).

KIPlink allows;

- Easy and enhanced unit management
- Real-Time graphs and key trends
- Different information for each kind of user

OPTIONAL ACCESSORIES – CLOUD PLATFORM: WEB SERVICES BASED ON CLOUD TECHNOLOGY FOR REMOTE MONITORING AND MANAGEMENT OF AIR CONDITIONING PLANTS.

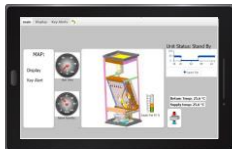

CLOUD PLATFORM is an ecosystem of web services for remote monitoring and management of air conditioning plants; specifically designed for mobile usage on tablets and smartphones, it allows to access plant data everywhere on the go so saving time, money and delivering a higher service level to the customer.

TECHNOLOGY

Based on cloud technology it allows, through machines data telemetry, to monitor and control units on the field, process data and perform proactive maintenance.

The hardware heart of the system is the Cloud box that can collect plant data (up to 31 devices and up to 1000 registers).

Connectivity between monitored devices and Cloud box may be wired in Ethernet, RS485, RS232 and must be in MODBUS protocol.

Cloud Platform then send these data to dedicated server in cloud in through the mobile (GPRS or 3G) network or ADSL.

Information security; each communication channel can be encrypted in VPN, ensuring data privacy.

USER SIDE

Cloud Platform is designed for mobile communication. So, the user just need a tablet or a smartphone to access the RC Cloud Platform and check his plant.

Cloud Platform App is available both on Android and iOS operating systems so the environment may be accessed directly from them beyond company site and platform site. Access through pc is available too.

FUNCTIONS

Telemetry & Data Export

Data polling and history of all data (1 year).
Export diagram and table (csv). **Your data always on the go.**

Multi Device

Many type of devices can be connected to the same box (chillers, close control, energy meters, flow meters, pumps,...).
Only a request: MODBUS protocol. Electrical connection in Ethernet, RS 485 or RS 232.

Multi Language

English native, Cloud Platform language pack is available for the main markets.

Virtual Display

Monitoring and control (on/off, alerts reset, main parameters change) as being beside the unit, in an augmented reality way.

Designed for Mobile.

Same as standing in front of the unit, when in your office or in any other place.

Internet Connectivity

ETHERNET + GPRS + 3G connection capability on Public and Virtual Private Network (VPN).

Alerts Warning through:

- Push notification
- e-mail
- Voice calls
- SMS

Processing of specialized plant KPI to get:

- Energy performance (gross instant EER)
- Components Failure Forecast (coming soon)
- Unit diagnosis

MACHINE DRAWINGS

Dimensions in mm - UNDER E4 – AIR HANDLING SECTION

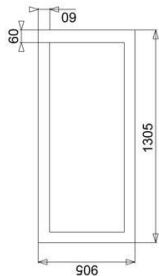

SUPERFICIE APPOGGIO A PAVIMENTO
FLOOR SUPPORT AREA

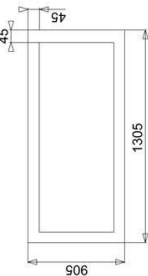

SUPERFICIE PER APPOGGIO PLENUM
PLENUM SUPPORT AREA

MODELLO / MODEL	DIA METRO CONNESSIONI CONNECTION DIAMETERS
w-NEXT2 S / K / DF E4	R 2"

- * CON SERRANDA DI NON RITORNO
ALTEZZA TOTALE = 2150
- * WITH NON RETURN MOTORIZED DAMPER
TOTAL HEIGHT= 2150

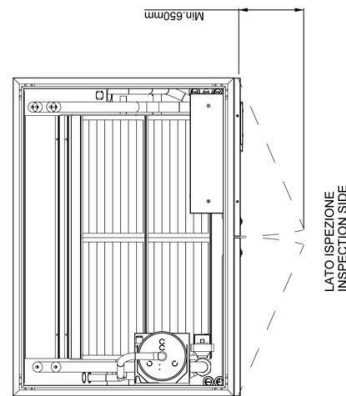
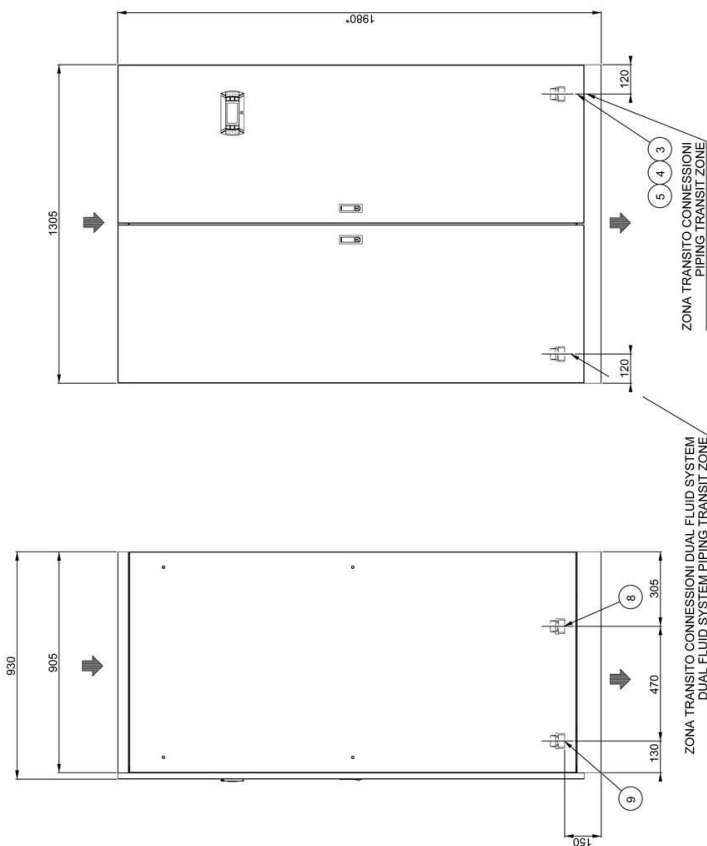
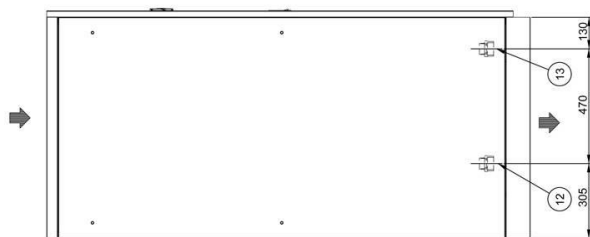

LATO ISPEZIONE
INSPECTION SIDE

CONNESSIONI / CONNECTIONS	
13	USCITA ACQUA DUAL FLUID SYSTEM / DUAL FLUID SYSTEM OUTLET
12	INGRESSO ACQUA DUAL FLUID SYSTEM / DUAL FLUID SYSTEM INLET
9	USCITA ACQUA REFRIGERATA / CHILLED WATER OUTLET
8	INGRESSO ACQUA REFRIGERATA / CHILLED WATER INLET
5	SCARICO ACQUA UMIDIFICATORE G 3/4" / HUMIDIFIER DRAIN G 3/4"
4	SCARICO ACQUA UMIDIFICATORE Ø 19mm / HUMIDIFIER DRAIN Ø 19mm
3	SCARICO CONDENSATE Ø 19mm / CONDENSATE DISCHARGE Ø 19mm

MACHINE DRAWINGS - Dimensions in mm - UNDER E4 – FAN SECTION

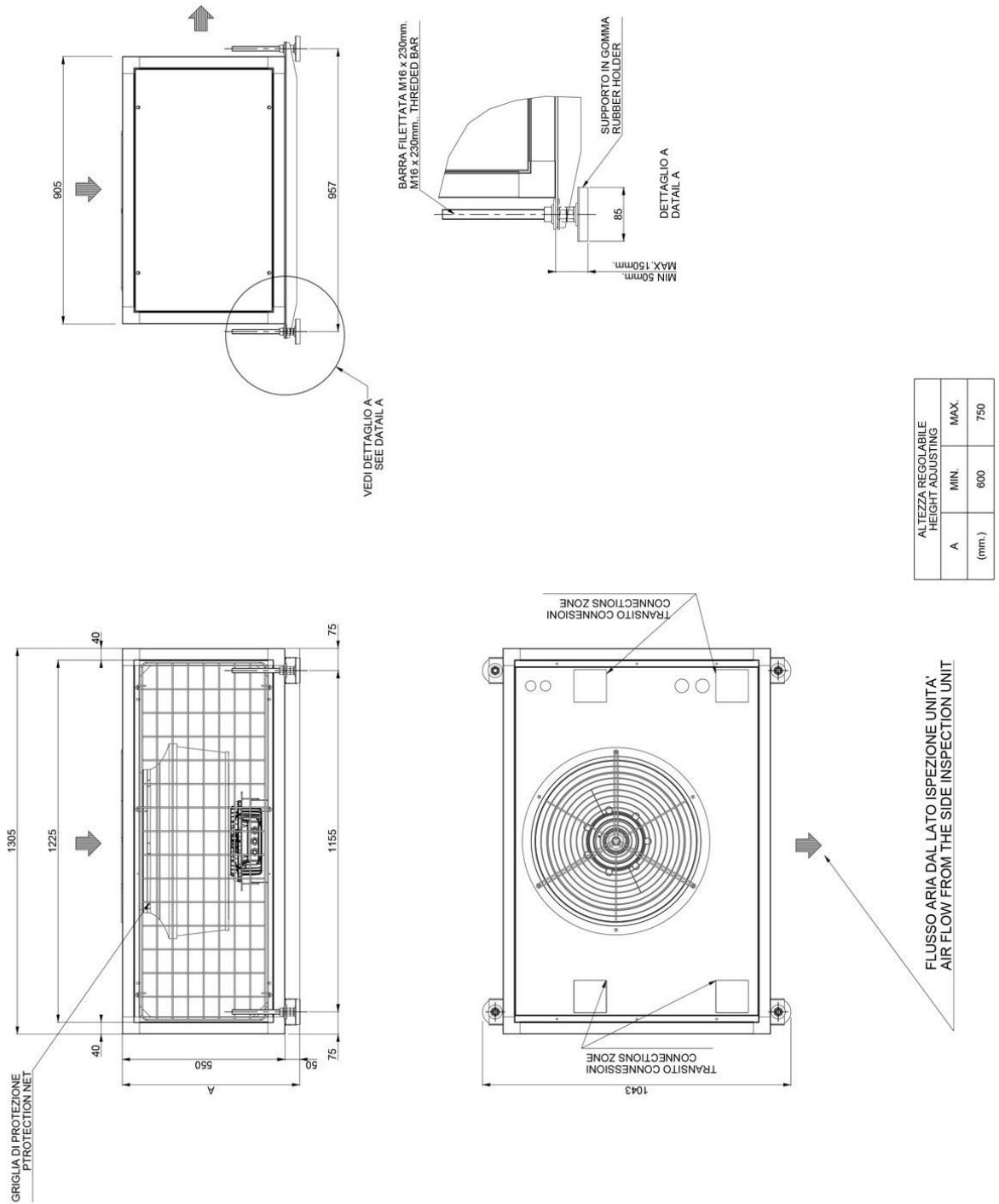

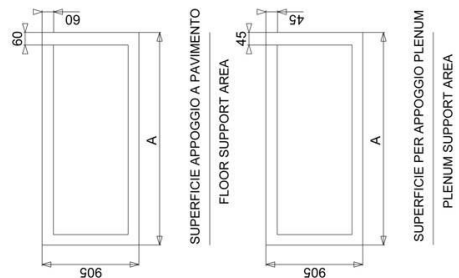

MODELLO / MODEL	A	DIAMETRO CONNESSIONI CONNECTION DIAMETERS
w-NEXT2 S / K / DF E5	1630	R 2"
w-NEXT2 S / K / DF E6	1873	R 2" 1/2

* CON SERRANDA DI NON RITORNO
ALTEZZA TOTALE = 2150

* WITH NON RETURN MOTORIZED DAMPER
TOTAL HEIGHT= 2150

CONNESSIONI / CONNECTIONS	
13	USCITA ACQUA DUAL FLUID SYSTEM / DUAL FLUID SYSTEM OUTLET
12	INGRESSO ACQUA DUAL FLUID SYSTEM / DUAL FLUID SYSTEM INLET
9	USCITA ACQUA REFRIGERATA / CHILLED WATER OUTLET
8	INGRESSO ACQUA REFRIGERATA / CHILLED WATER INLET
5	INGRESSO ACQUA REFRIGERATA / CHILLED WATER INLET
4	SCARICO ACQUA UMIDIFICATORE Ø 3/4" / HUMIDIFIER DRAIN Ø 3/4"
3	SCARICO CONDENSATA Ø 15mm. / CONDENSATE DISCHARGE Ø 15mm.

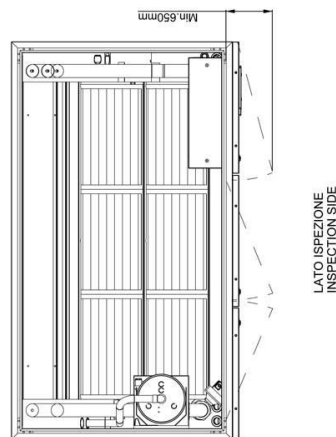
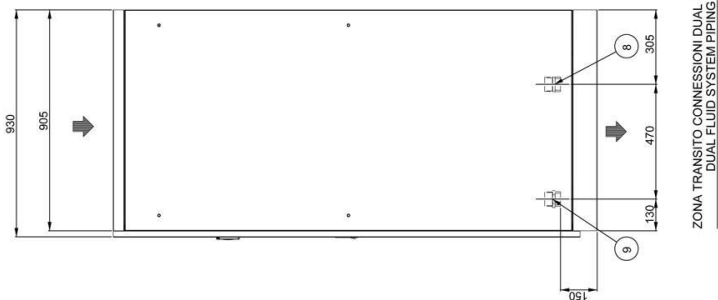
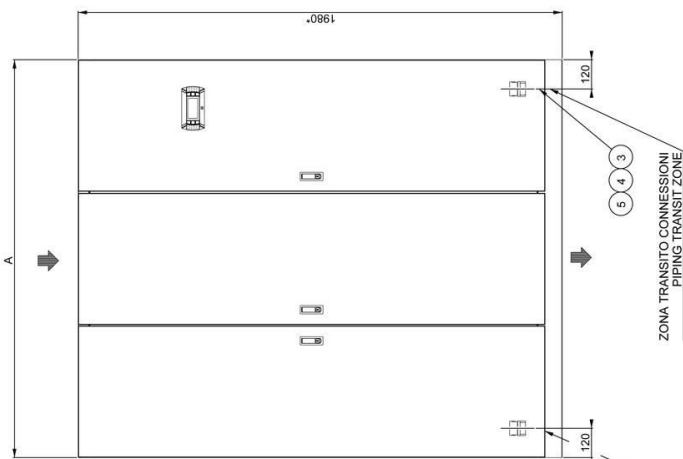
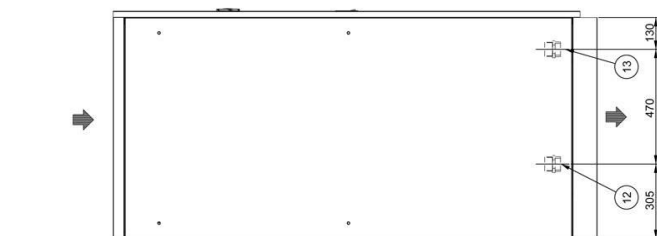

MACHINE DRAWINGS - Dimensions in mm - UNDER E5 – FAN SECTION

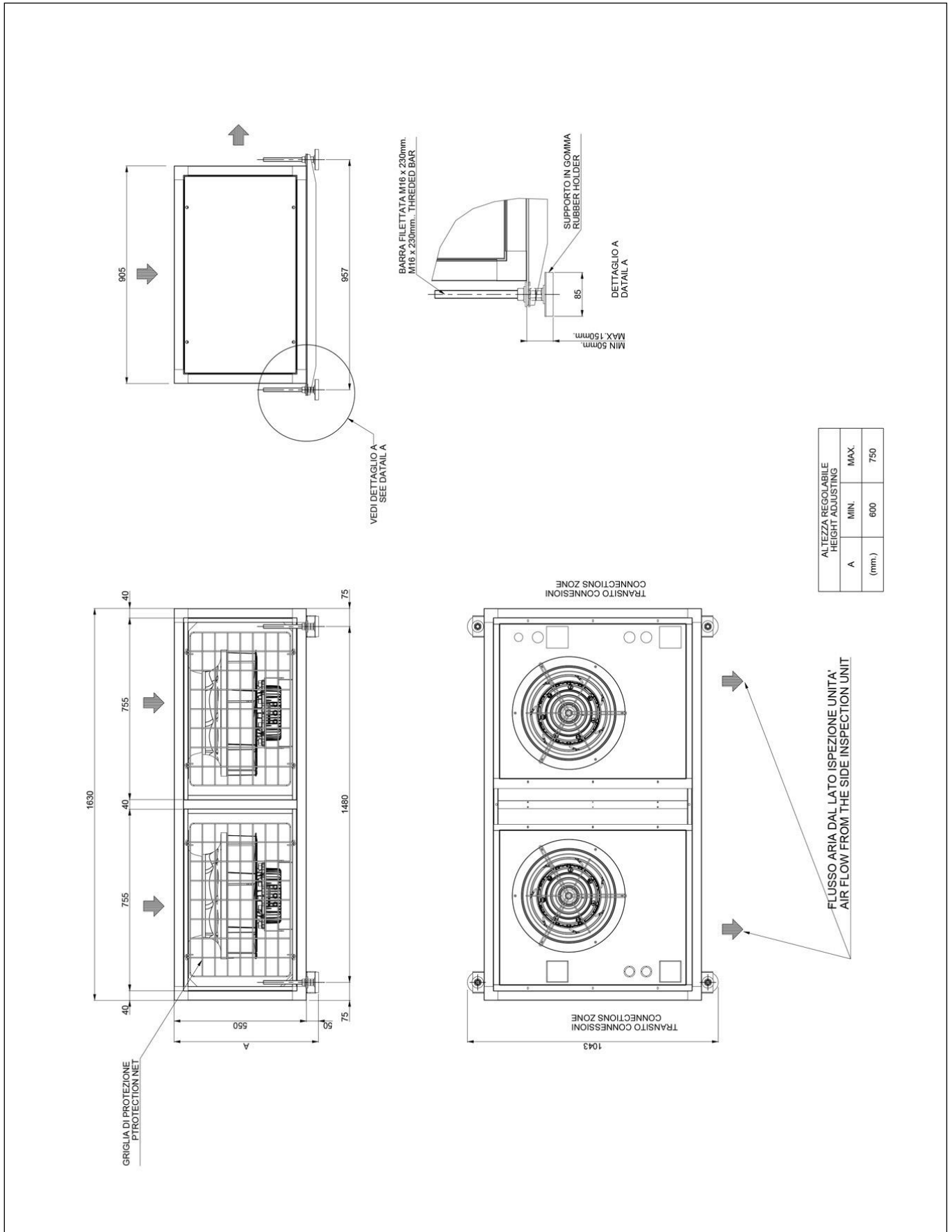

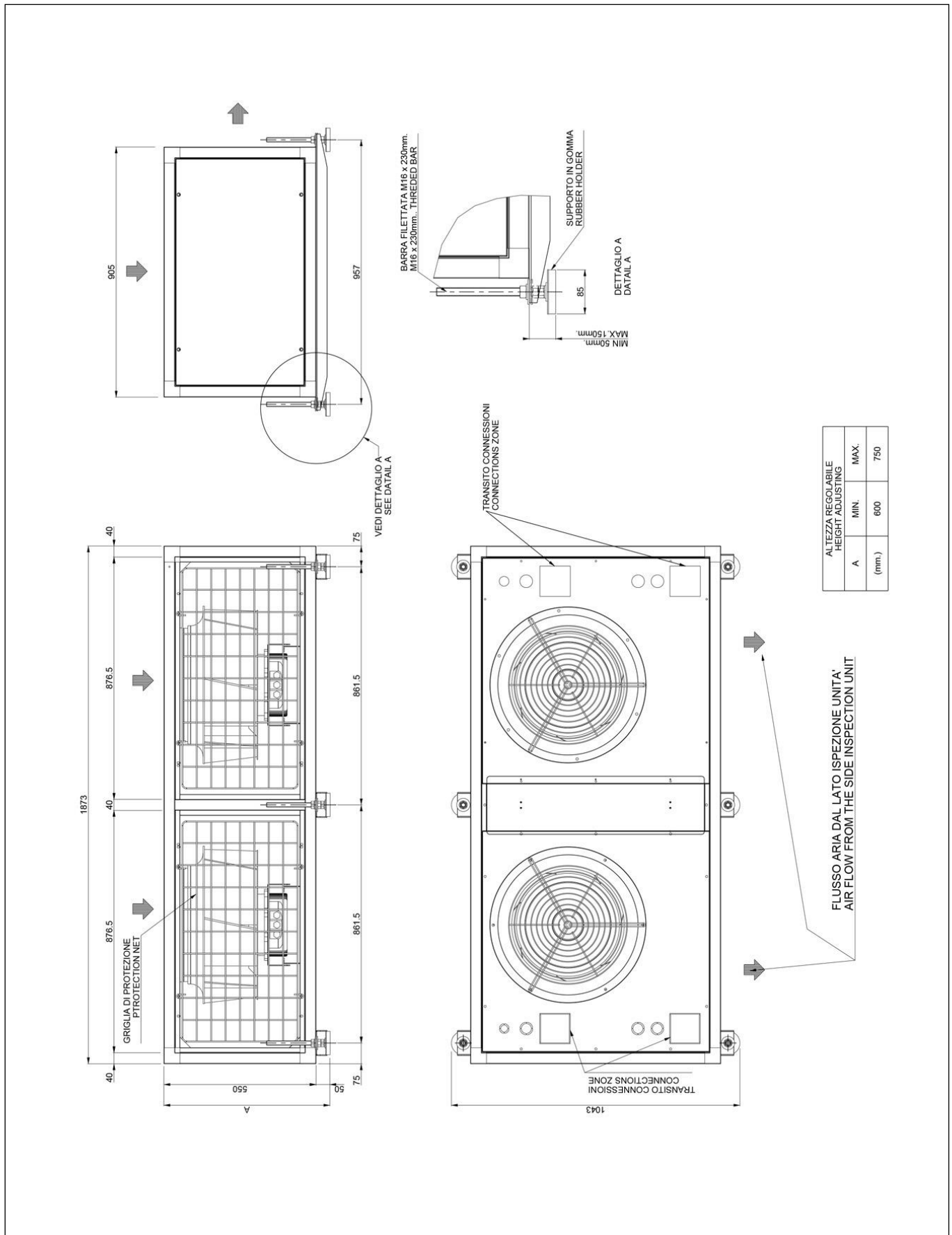

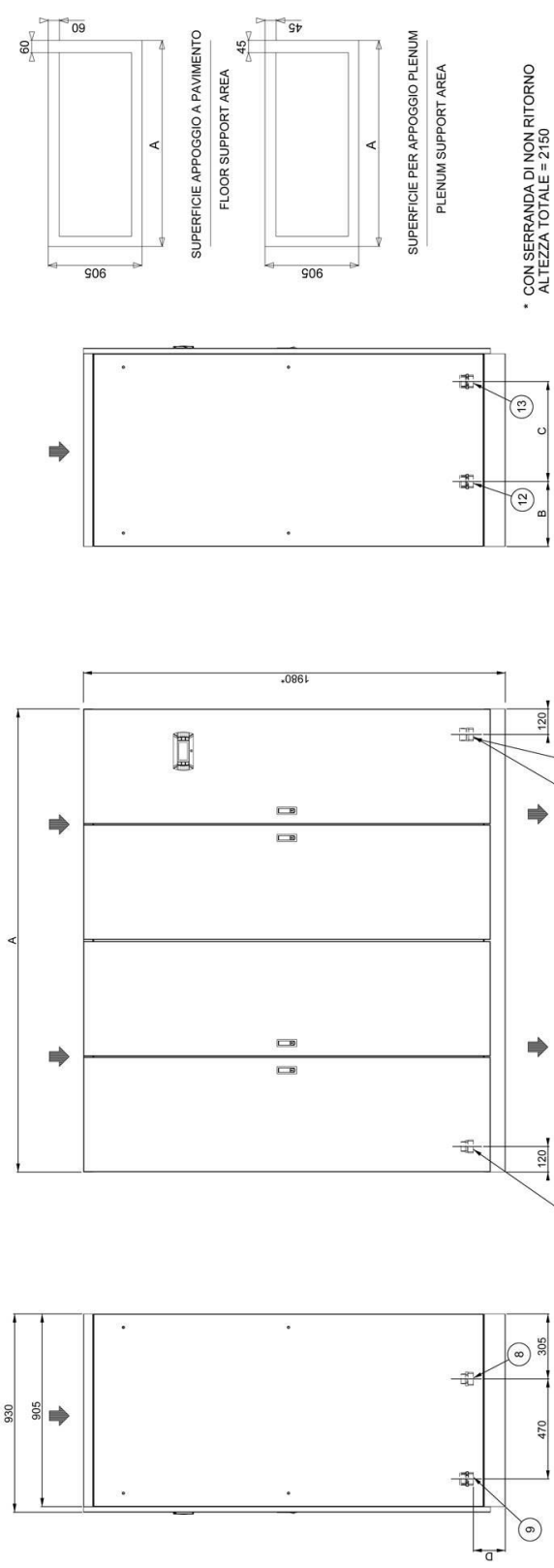

* CON SERRANDA DI NON RITORNO
ALTEZZA TOTALE = 2150

* WITH NON RETURN MOTORIZED DAMPER
TOTAL HEIGHT= 2150

MODELLO / MODEL	A	B	C	D	DIAMETRO/CONNESSIONI CONNECTION DIAMETERS
w-NEXT2 S / DF E7	2175	305	470	150	R 2" 1/2
w-NEXT2 K E7	2175	305	470	120	R 3"
w-NEXT2 S / DF E8	2499	305	470	125	R 3"
w-NEXT2 K E8	2499	305	470	125	R 3"
w-NEXT2 S / DF E9	2899	280	495	125	R 3"
w-NEXT2 K E9	2899	280	495	180	DN 80

CONNESSIONI / CONNECTIONS	
13	USCITA ACQUA DUAL FLUID SYSTEM DUAL FLUID SYSTEM OUTLET
12	INGRESSO ACQUA DUAL FLUID SYSTEM DUAL FLUID SYSTEM INLET
9	USCITA ACQUA REFRIGERATA CHILLED WATER OUTLET
8	INGRESSO ACQUA REFRIGERATA CHILLED WATER INLET
5	ALIMENTAZIONE ELETTRICA POWER SUPPLY
4	SCARICO ACQUA UMIDIFICATORE HUMIDIFIER DRAIN Ø 19mm
3	SCARICO CONDENSATE CONDENSATE DISCHARGE Ø 19mm

ZONA TRANSITO CONNESSIONI PIPING TRANSIT ZONE

ZONA TRANSITO CONNESSIONI DUAL FLUID SYSTEM DUAL FLUID PIPING TRANSIT ZONE

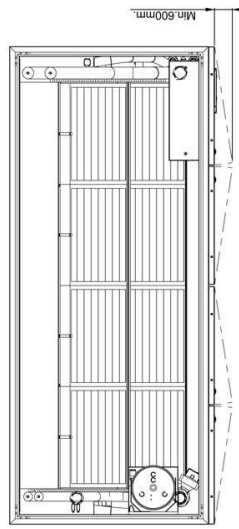

LATO ISPEZIONE INSPECTION SIDE

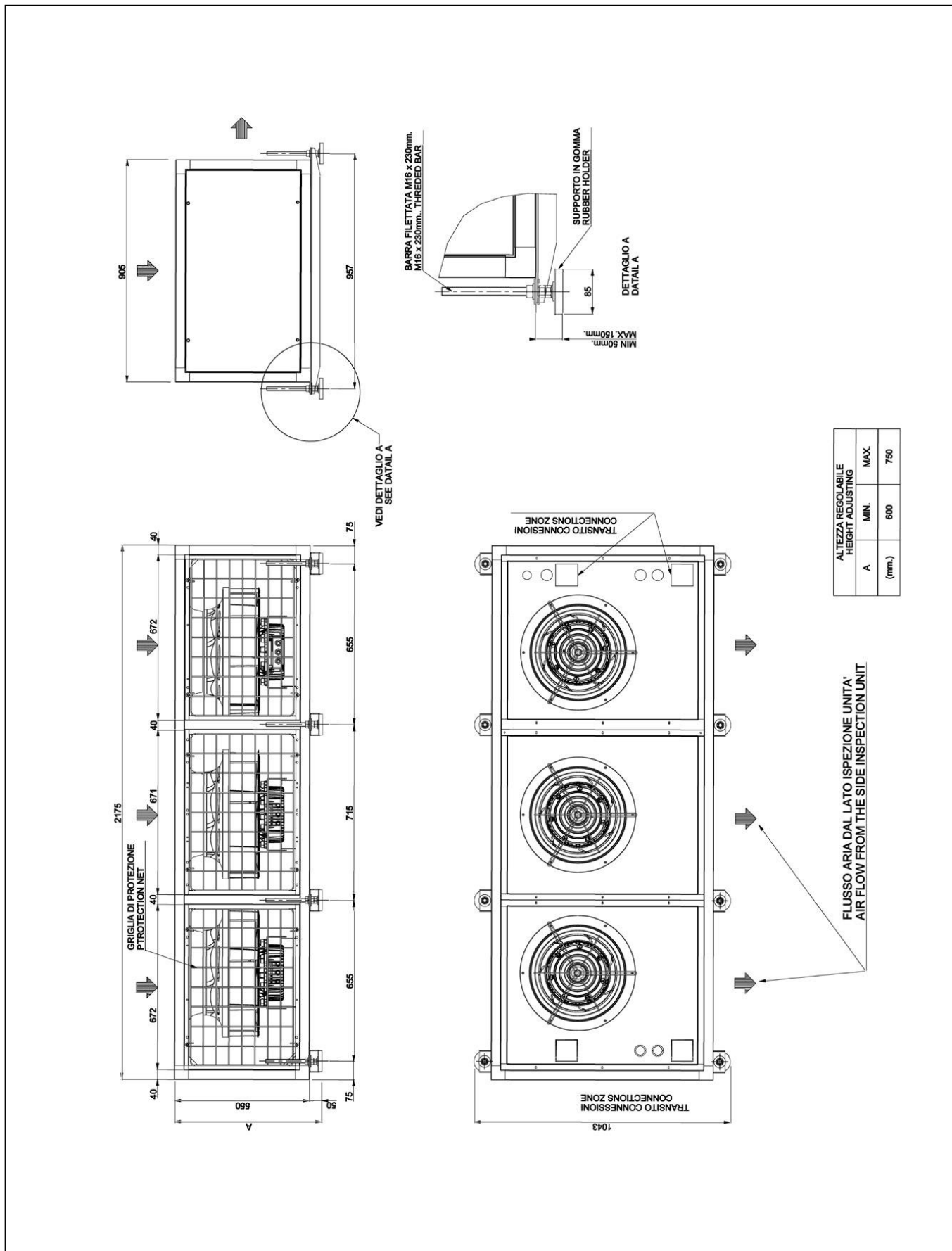

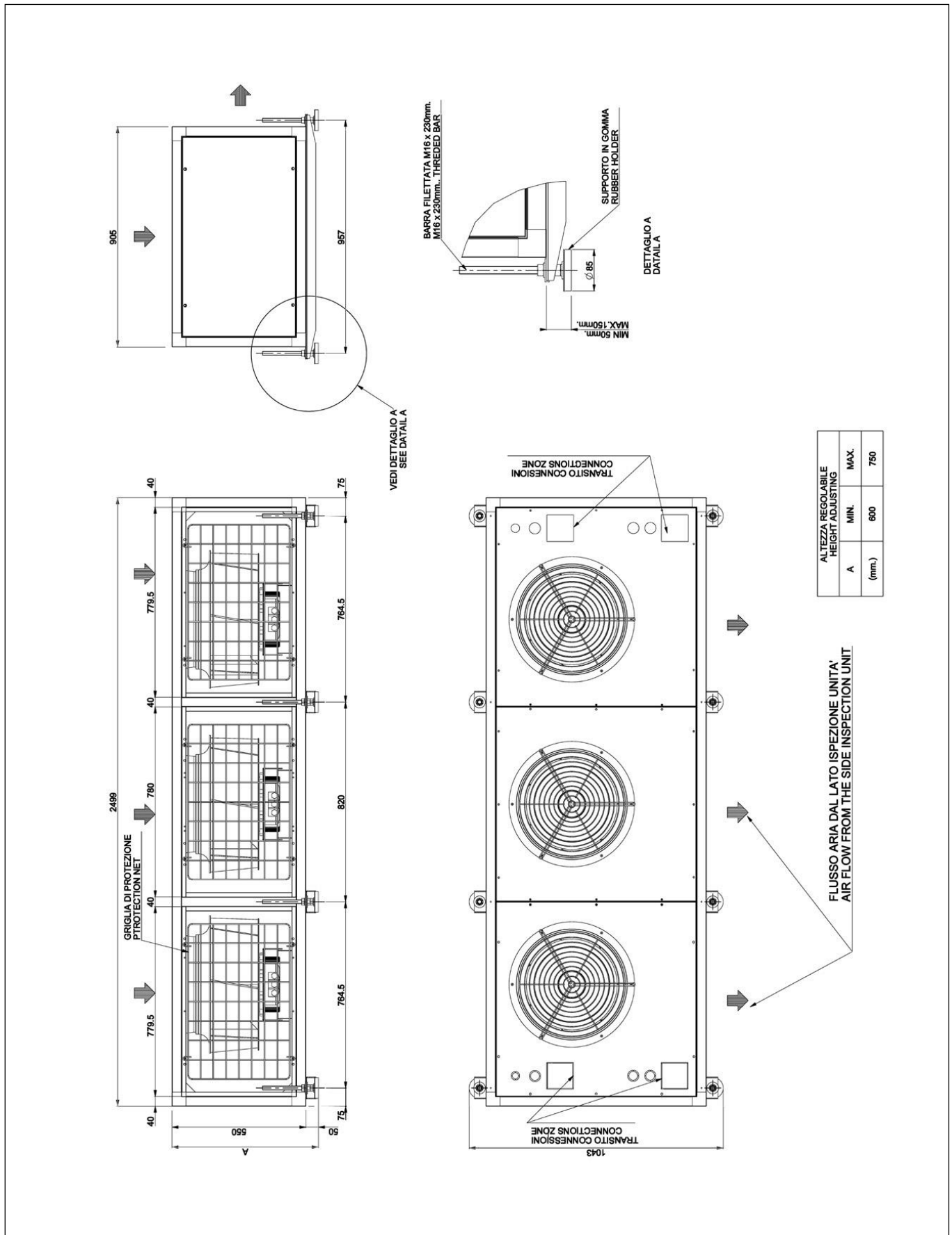

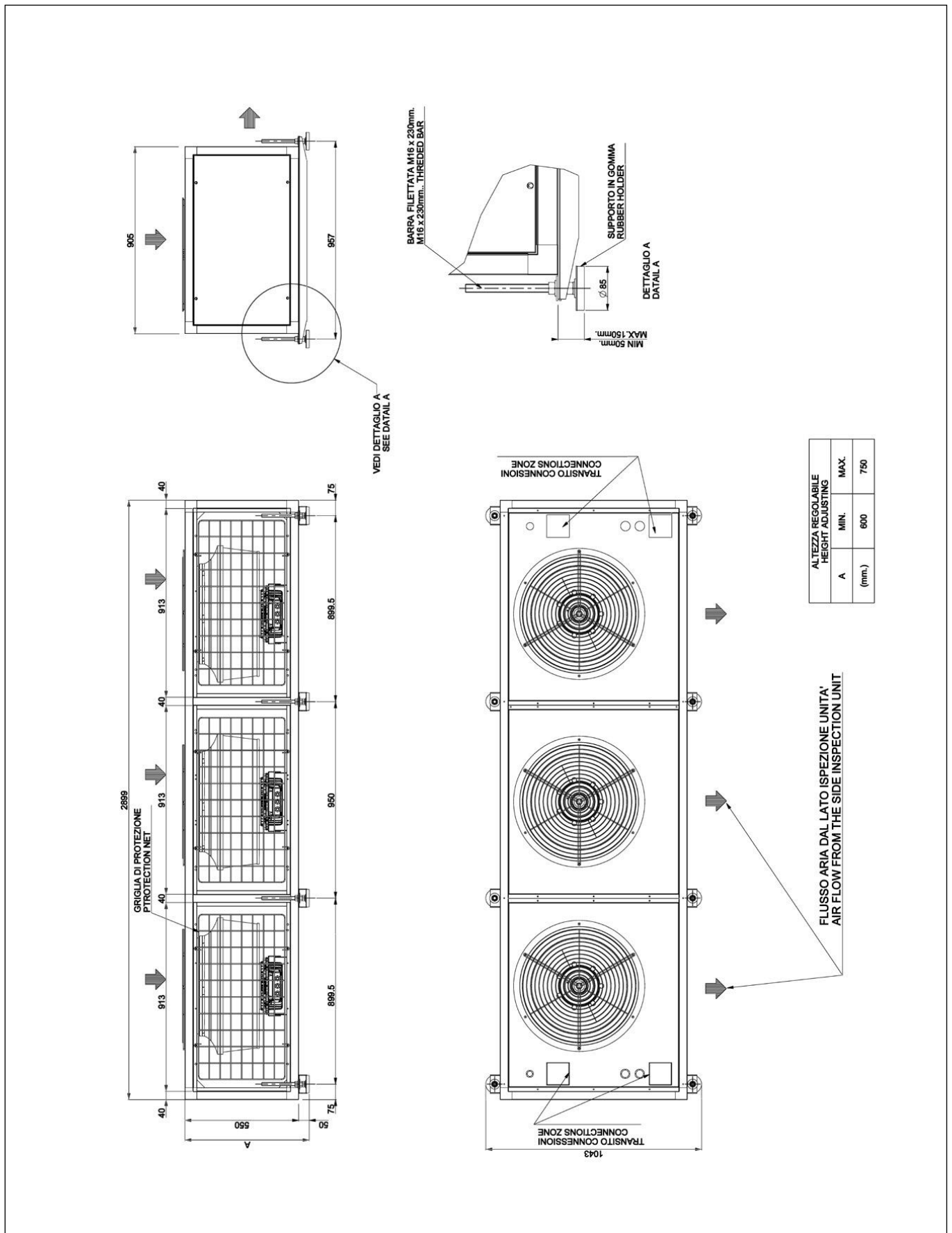

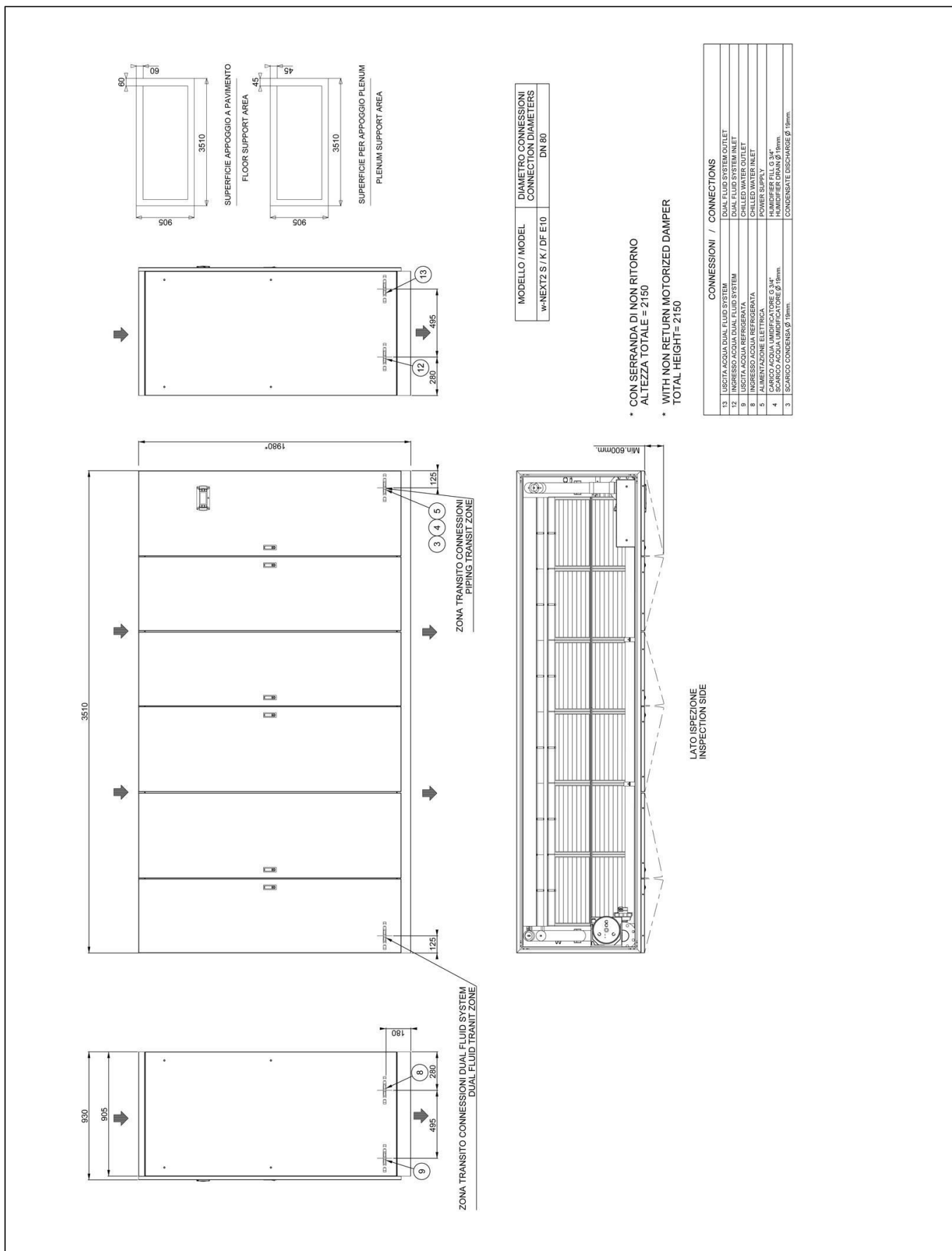

MODELLO / MODEL	DIAMETRO CONNESSIONI CONNECTION DIAMETERS
w-NEXT2 S / K / DF E10	DN 80

* CON SERRANDA DI NON RITORNO
 ALTEZZA TOTALE = 2150
 * WITH NON RETURN MOTORIZED DAMPER
 TOTAL HEIGHT= 2150

CONNESSIONI / CONNECTIONS	CONNESSIONI / CONNECTIONS
13 USCITA ACQUA DUAL FLUID SYSTEM / DUAL FLUID SYSTEM OUTLET	DUAL FLUID SYSTEM OUTLET
12 INGRESSO ACQUA DUAL FLUID SYSTEM / DUAL FLUID SYSTEM INLET	CHILLED WATER INLET
9 USCITA ACQUA REFRIGERATA / CHILLED WATER OUTLET	CHILLED WATER INLET
8 INGRESSO ACQUA REFRIGERATA / CHILLED WATER INLET	CHILLED WATER INLET
5 USCITA ACQUA REFRIGERATA / CHILLED WATER OUTLET	CHILLED WATER INLET
4 SCARICO ACQUA UMIDIFICATORE Ø 3/4" / HUMIDIFIER DRAIN Ø 3/4"	HUMIDIFIER DRAIN Ø 18mm
3 SCARICO CONDENSATE Ø 18mm / CONDENSATE DISCHARGE Ø 18mm	HUMIDIFIER DRAIN Ø 18mm

ZONA TRANSITO CONNESSIONI DUAL FLUID SYSTEM / DUAL FLUID TRANSIT ZONE

ZONA TRANSITO CONNESSIONI / PIPING TRANSIT ZONE

LATO ISPEZIONE / INSPECTION SIDE

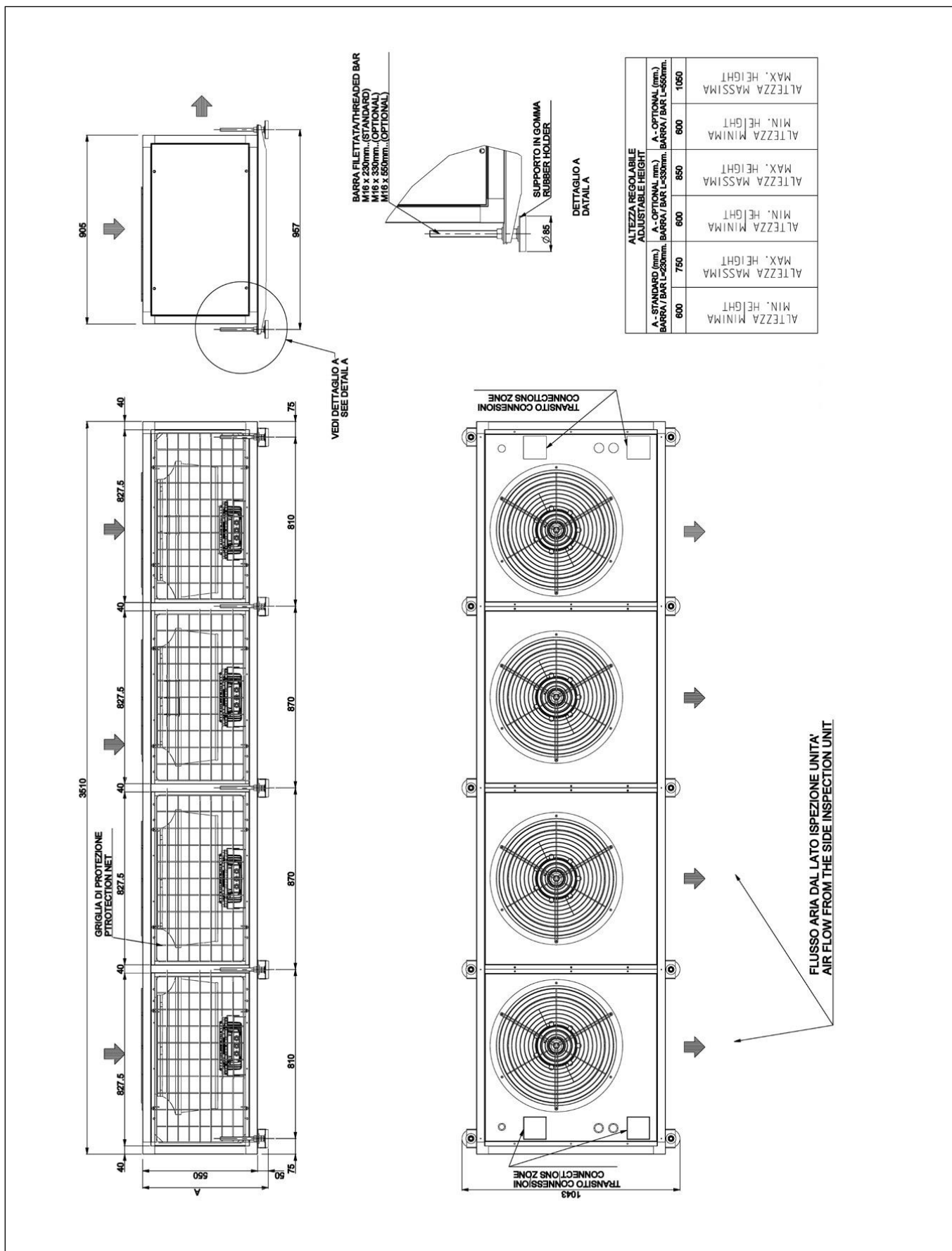

HOLE IN THE RAISED FLOOR

HOLE IN THE RAISED FLOOR

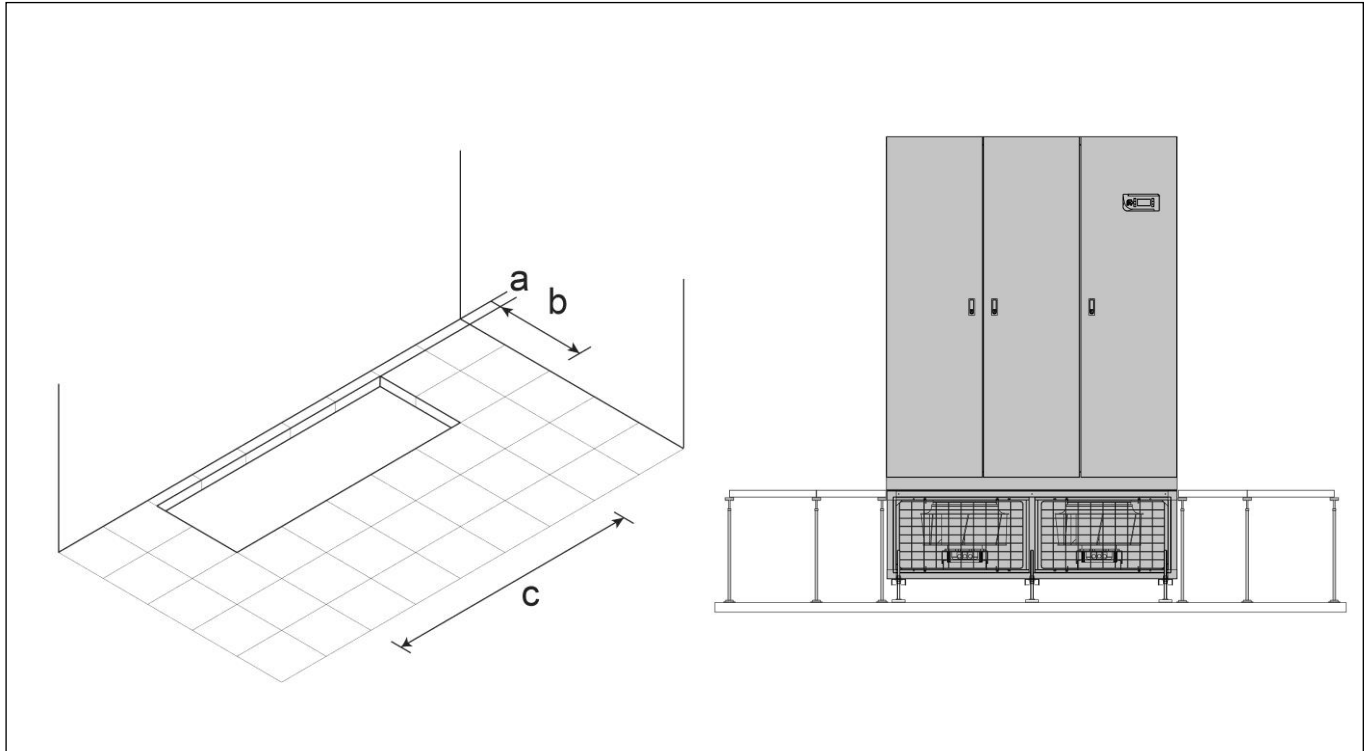

Foresee a hole in the floor with the following dimensions:

SIZE		E4	E5	E6	E7	E8	E9	E10
VERSION (1)		U	U	U	U	U	U	U
a	mm	80	80	80	80	80	80	80
b	mm	925	925	925	925	925	925	925
c	mm	1325	1650	1895	2195	2520	2920	3530

1. U = Under, downflow / O = Over, upflow

EXAMPLE FOR MACHINES NOISE EMISSION CALCULATION

UNDER MACHINE WITH DUCT ON AIR INTAKE

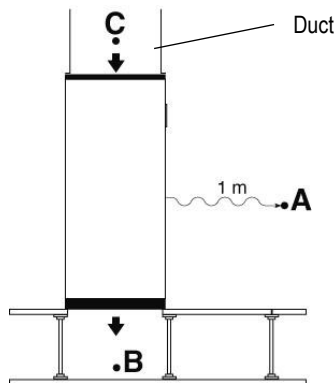

- Lp A = Front side Under catalogue value
- Lp B = Air delivery Under catalogue value
- Lp C = Air intake Under catalogue value
- The points B and C do not influence the point A

UNDER MACHINE WITH PLENUM ON AIR DELIVERY

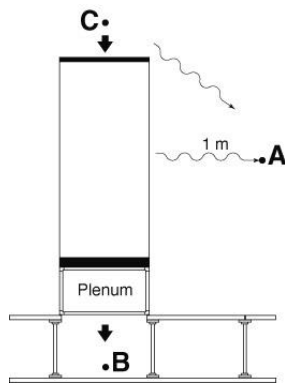

- Lp A = Front side Under catalogue value
- Lp B = Air delivery Under catalogue value – plenum noise reduction
- Lp C = Air intake Under catalogue value
- $Lp A+C = 10 \log_{10} \left(10^{\frac{LpA}{10}} + 10^{\frac{LpC}{10}} \right)$
- The point B do not influence the point A

UNDER MACHINE WITH PLENUM ON AIR INTAKE

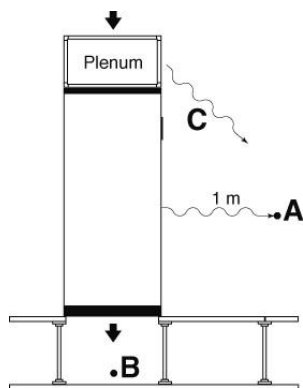

- Lp A = Front side Under catalogue value
- Lp B = Air delivery Under catalogue value
- Lp C = Air intake Under catalogue value – plenum noise reduction
- $Lp A+C = 10 \log_{10} \left(10^{\frac{LpA}{10}} + 10^{\frac{LpC}{10}} \right)$
- The point B do not influence the point A

IMPORTANT

The declared noise levels are intended in free field conditions.
 The noise pressure level of an installed unit is affected by the room acoustic characteristics.
 Please consider an average noise increase of +4/+6 dB(A).

VALVE PRESSURE DROP CALCULATION AS FUNCTION OF WATER FLOW RATE

Flow coefficient k_v defines the water flow (between 5°C and 40°C) expressed in m³/h that cross a valve with a pressure drop of 1bar (100kPa).

With this data is possible to calculate the localized pressure drop as function of the water flow rate.

$$\Delta P = (Q / k_v)^2$$

ΔP (bar) = localized pressure drop of valve;

Q (m³/h) = water flow rate – it varies according to the desired operating condition;

k_v (m³/h) = valve flow coefficient.

The formula allows to calculate the value of the localized pressure drop (in bar).

The pressure drops values showed on the documentation are supplied in kPa.

Is possible to change from one unit to another through the following conversion.

$$1 \text{ bar} = 100\text{kPa}$$

CALCULATION EXAMPLE OF 2-WAY VALVE FOR BY-PASS PRESSURE DROP IN FUNCTION OF WATER FLOW RATE

Model 127 E7

Example at nominal conditions. Characteristics referred to entering air at 24°C-50%RH with chilled water temperature 7-12°C - 0% glycol.

Water flow rate: 21,9 m³/h

Valve flow coefficient k_v : 25 m³/h

$$\text{2-way valve for by-pass pressure drop: } \Delta P = (Q / k_v)^2 = (21,9 / 25)^2 = 0,767 \text{ (bar)} * 100 \text{ (kPa / bar)} = 76,7 \text{ kPa}$$



for a greener tomorrow

Eco Changes is the Mitsubishi Electric Group's environmental statement, and expresses the Group's stance on environmental management. Through a wide range of businesses, we are helping contribute to the realization of a sustainable society.



MITSUBISHI ELECTRIC HYDRONICS & IT COOLING SYSTEMS S.p.A.

Via Caduti di Cefalonia, 1 - 36061 Bassano del Grappa (VI) Italy
Ph. (+39) 0424 509 500 • Fax (+39) 0424 509 509
www.melcohit.com